

Chapter4

Failure

강의명: 기계재료공학 (MFA9009)

정영웅

창원대학교 신소재공학부

YJEONG@CHANGWON.AC.KR

연구실: #52-208 전화: 055-213-3694

HOME PAGE: [HTTP://YOUNGUNG.GITHUB.IO](http://youngung.github.io)

Recap

- Learned mechanical properties
- Uniaxial tension tests provides
 - Yield strength
 - Elastic modulus
 - Ultimate tensile strength
 - Ductility
 - **Toughness**
 - Area under the stress-strain curve
 - Energy required to break a material into two separate pieces.

Objectives and outlines

- Failure: occurs by three main mechanisms
 - Fracture (파괴), noncyclic σ and $T < 0.4T_m$
 - Fatigue (피로, noncyclic σ)
 - Creep (크리프, $T < 0.4T_m$)
- Fractography
- Fracture (파괴)
 - Brittle fracture
 - Ductile fracture
 - DBTT
 - Basic Fracture mechanics and application to design problems
- Fatigue
 - Failure under stress far below YS, TS; Cyclic loading
- Creep
 - Time dependent permanent deformation

Fundamentals of Fracture

- Simple fracture is the separation of a body into two (or more) pieces; 정적인 힘이 가해져 발생하거나 혹은
 - Fatigue
 - Creep 에 의해서도 발생
 - Tensile, shear, 혹은 compression 모두 파괴로 이어질 수 있지만, 우리는 일축 인장에 한정하여 다루도록 한다.
- Two case of fracture
 - Ductile (연성 파괴)
 - Brittle (취성 파괴)
 - 재료의 '소성 가공성' 즉 얼마나 많은량의 소성 변형을 일으킬 수 있는지에 따라 바뀐다.
 - Note: 일축 인장시 %EL 그리고 %RA는 재료에 따라 다르다.

Fundamentals of Fracture

- Ductile fracture: 상당히 높은 에너지를 흡수한 뒤에야 파괴
- Brittle fracture: 소성변형이 일어나지 않거나, 혹은 매우 제한적인 양으로.

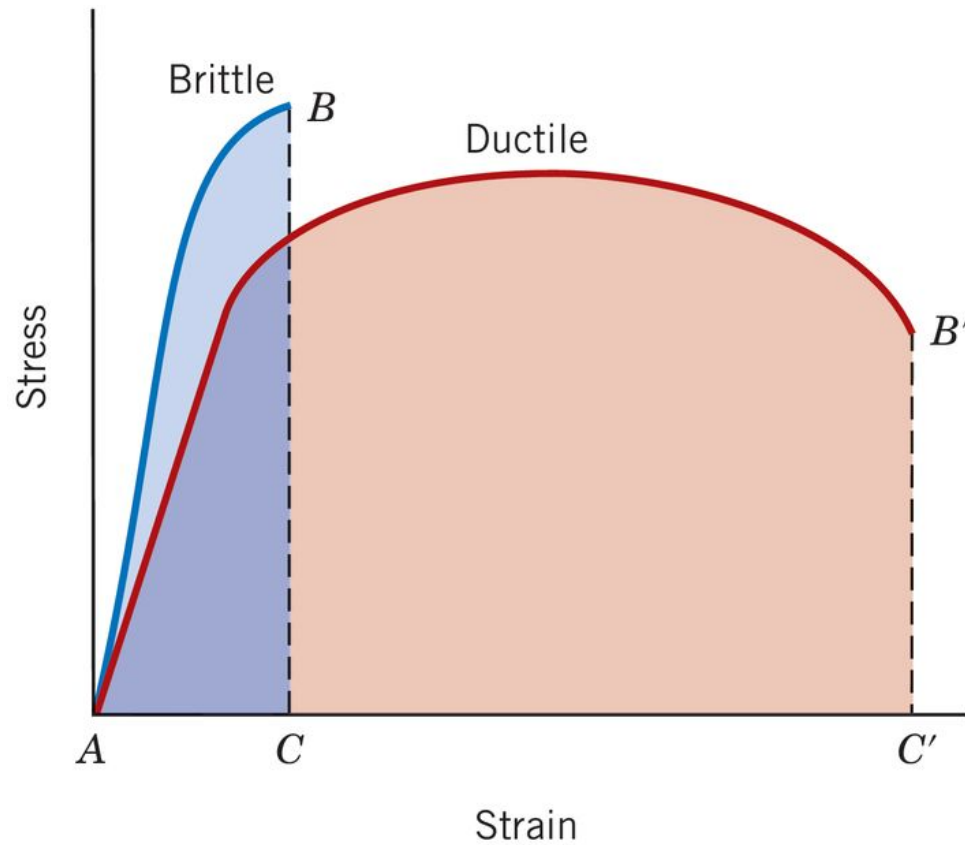

Crack formation and propagation

- 미시적으로 살펴보면 파괴는 두 단계로 이루어진다.
 - 1. 균열 (crack) 생성
 - 2. 균열의 전파 (propagation)
- The mode of fracture (파괴형태)는 균열의 전파 방식에 의해 결정
 - 균열이 천천히 진전; Stable; 이 경우 파괴 발생까지 상당한 소성변형량이 필요; No stress No propagation
 - 균열이 빠르게 진전; Unstable; Little plastic deformation; 작용 응력이 증가하지 않아도 진전 가능
- Q) Which type of fracture is preferred?
 - A) Ductile fracture; Because it 'warns' you.

Ductile vs Brittle fracture

Fracture behavior:

Very Ductile

Moderately Ductile

Brittle

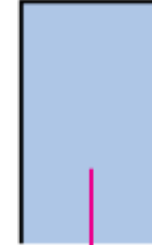
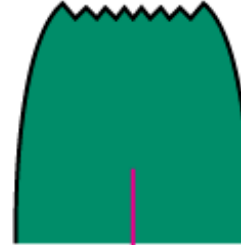
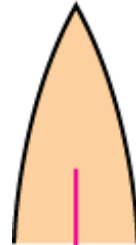
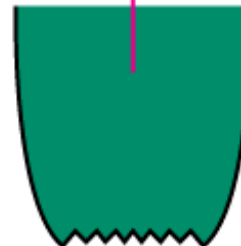
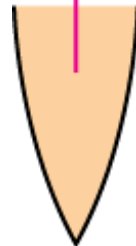

$\%RA$ or $\%EL$

Large

Moderate

Small

Soft metals
(Au, Pb)
Materials at
High T.

Typical for
ductile metals

Metals at low T.
Ceramics



Examples: pipe failures

- **Ductile failure:**
 - one piece
 - large deformation

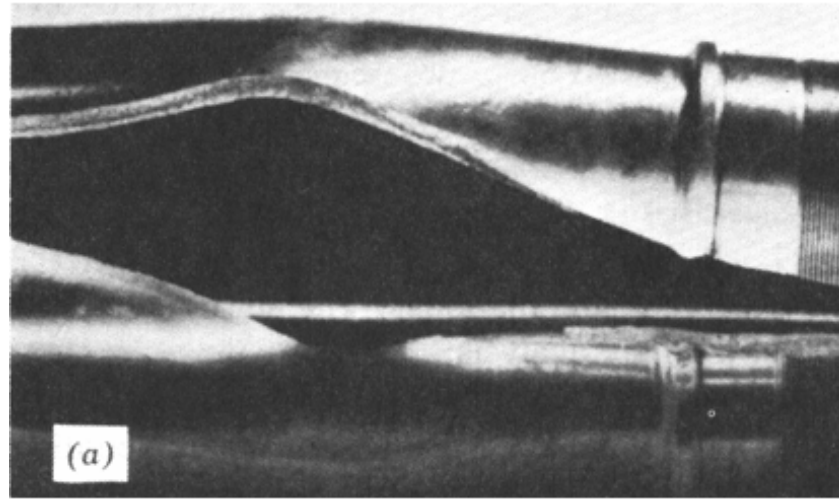

- **Brittle failure:**
 - many pieces
 - small deformations

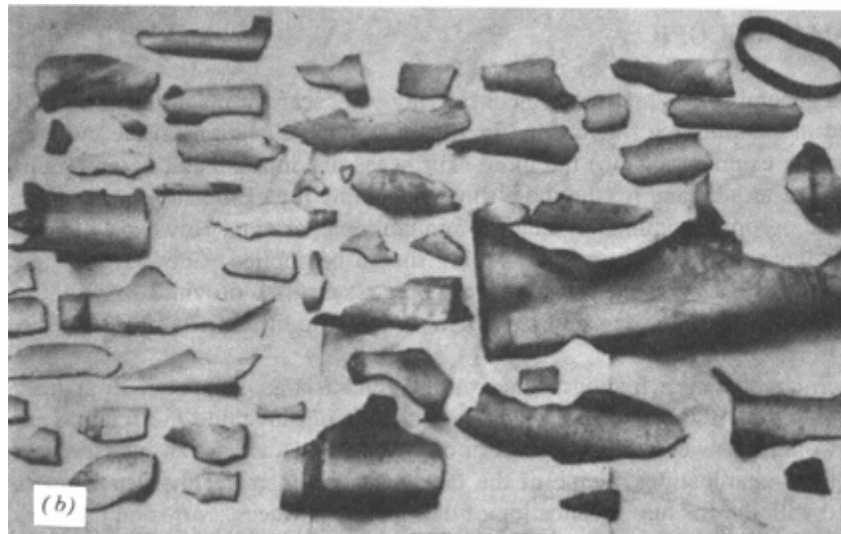

Figures from V.J. Colangelo and F.A. Heiser, *Analysis of Metallurgical Failures* (2nd ed.), Fig. 4.1(a) and (b), p. 66 John Wiley and Sons, Inc., 1987. Used with permission.

Ductile fracture characteristics

- Failure Stages:

necking

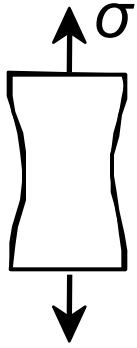

void nucleation



void growth and coalescence



shearing at surface



fracture

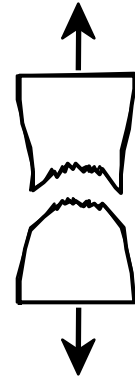

Cup and Cone
(컵-원뿔 파괴)



Sheared zone
45° to tensile
force

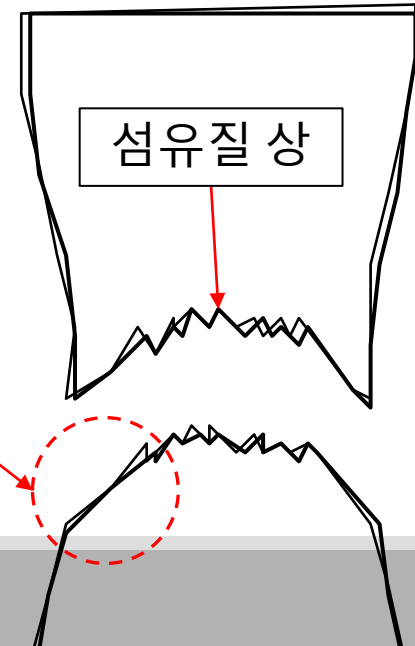

Fractography (ductile fracture)

- Fractography (fracture+graph ; 파괴면 연구; 파괴사진학)
 - 파괴의 단면으로, 파괴 형태, 응력 상태, 균열의 시작 위치 등 파악 가능
- SEM (scanning electron microscope)
 - 앞서 말한 '섬유질상'을 고배율로 살펴볼 수 있다.

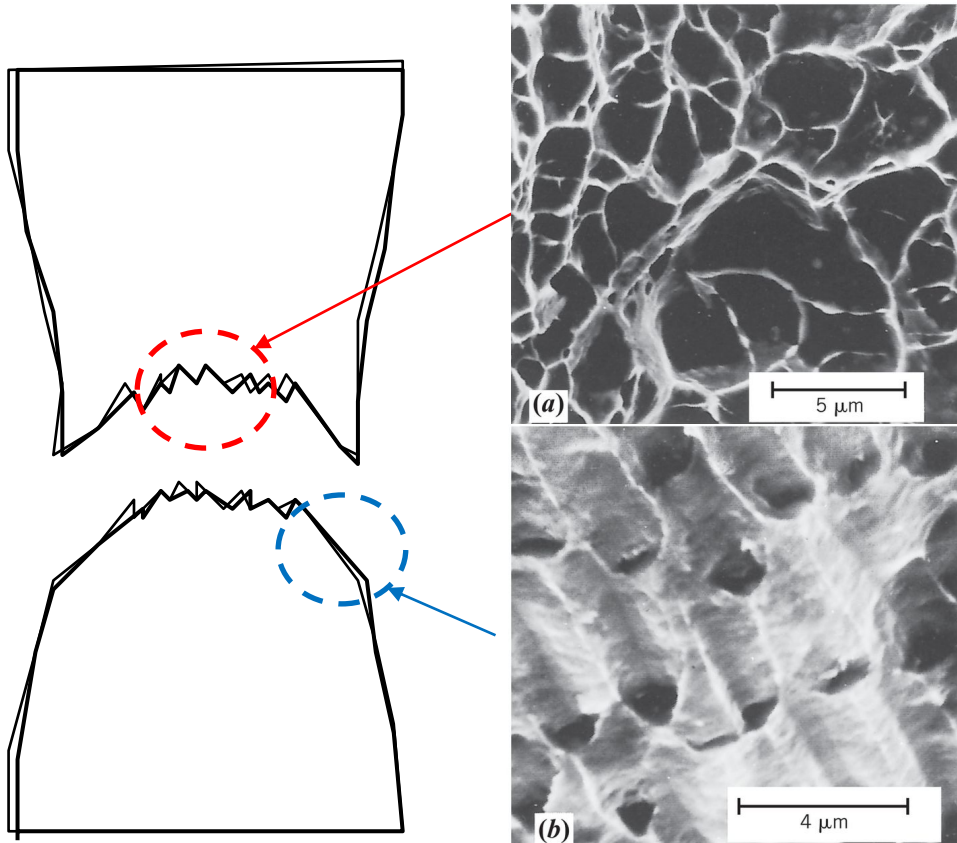

섬유질상
Ductile fracture under
'uniaxial tension'

Ductile fracture under 'shear'

한쪽으로
늘어난 모양

Fractography (brittle fracture)

Failure origin

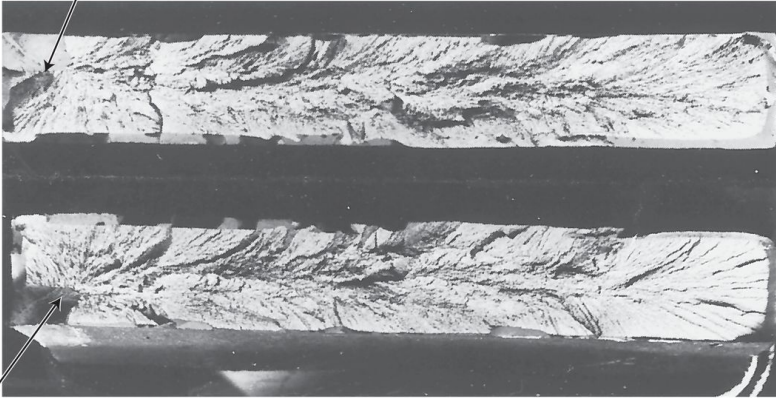

Chevron Marking: 웨브론 표시
(chevron: 갈매기 표기; 상사 계급표?)

(a)

Failure origin

Failure origin

방사형, 부채꼴 형 (fan) 전파



(b)

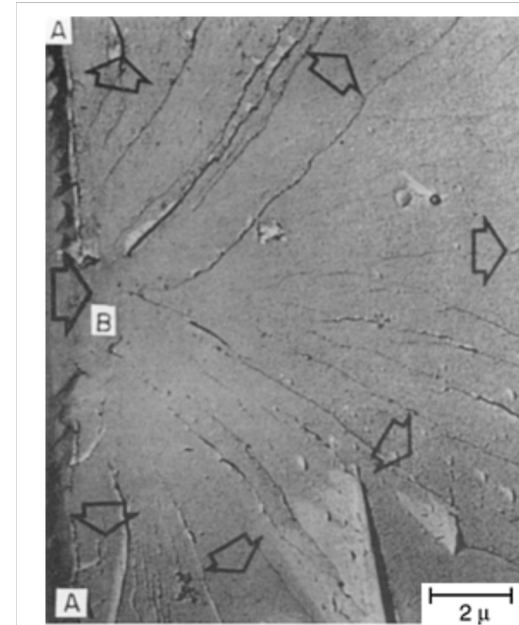

(a) From R. W. Hertzberg, Deformation and Fracture Mechanics of Engineering Materials, 3rd edition. Copyright © 1989 by John Wiley & Sons, New York. Reprinted by permission of John Wiley & Sons, Inc. Photograph courtesy of Roger Slutter, Lehigh University. (b) From D. J. Wulpi, Understanding How Components Fail, 1985. Reproduced by permission of ASM International, Materials Park, OH.

Brittle fracture

- 취성 파괴는 소성변형의 흔적이 거의 없다.
- Cleavage 파손 (fast fracture에서 보이는 특징; cleavage: sharp division)
 - 취성 결정 재료의 균열 전파는 특정 결정면 (crystal plane)을 따라 발생.
 - 따라서 grain을 가로질러 균열이 전파 따라서 transgranular 즉, 결정립 내부를 '관통'
 - Grainy (알갱이가 보이는 형상), 혹은 faceted texture; (facet: 깎은 면)

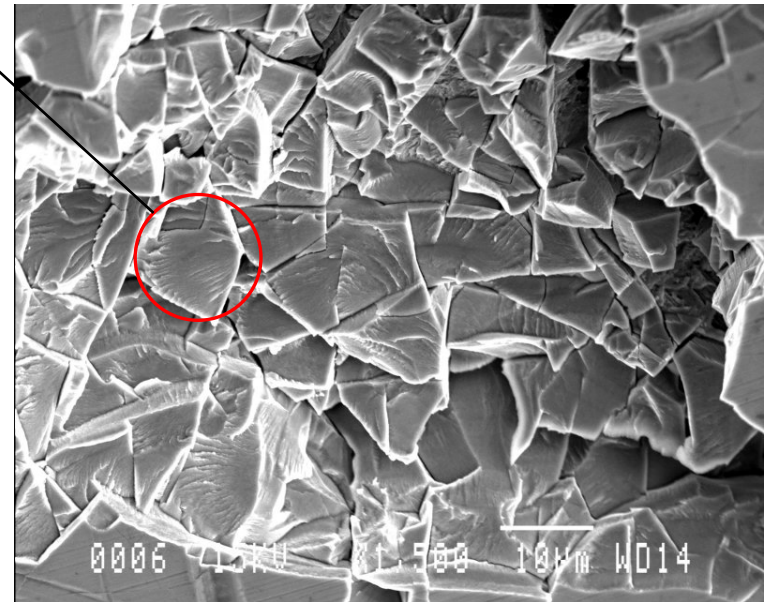

Cleavage on intersecting {100} planes in bcc Cr.

Transgranular and Intergranular

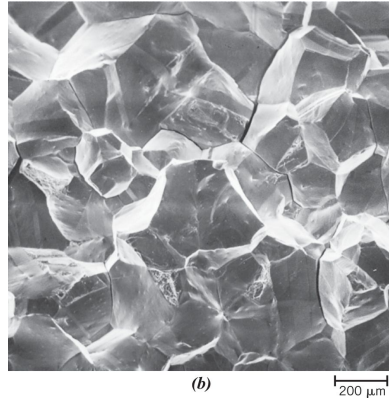
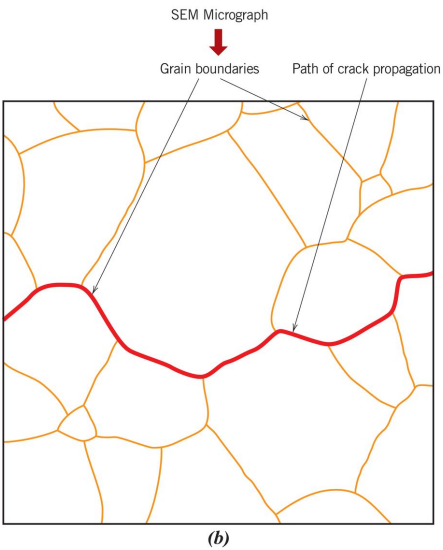

Figure (b) reproduced with permission from ASM Handbook, Vol. 12, Fractography, ASM International, Materials Park, OH, 1987.

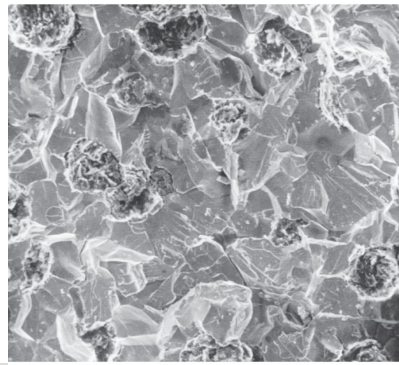
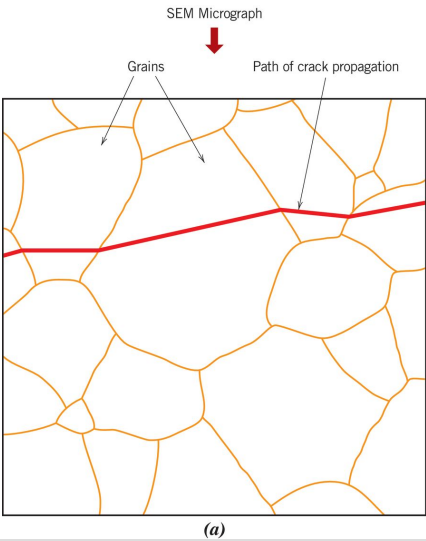
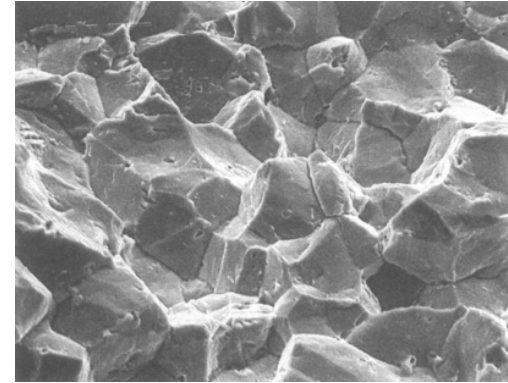
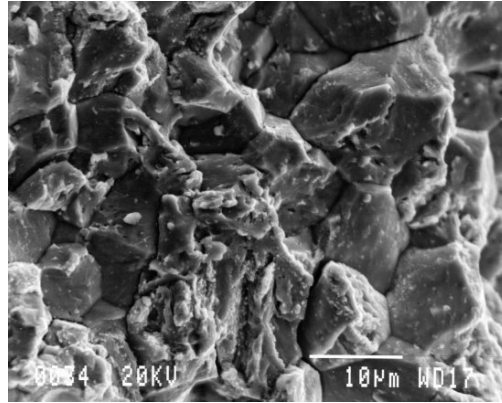
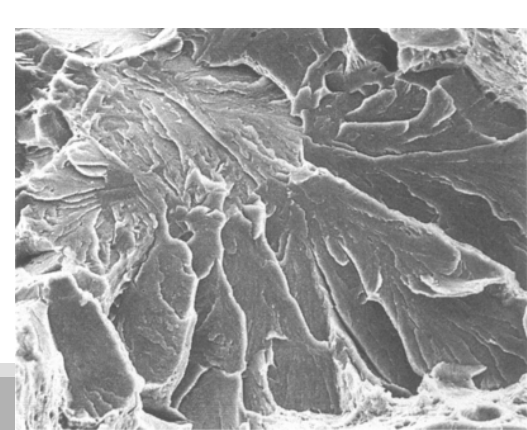
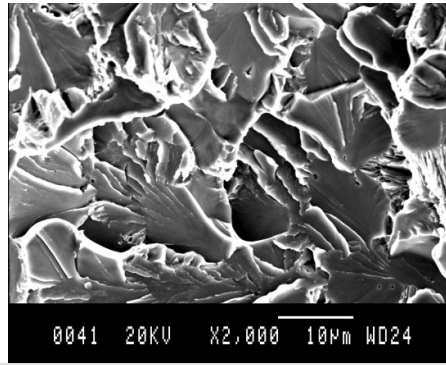

Figure (b) from V. J. Colangelo and F. A. Heiser, Analysis of Metallurgical Failures, 2nd edition. Copyright © 1987 by John Wiley & Sons, New York. Reprinted by permission of John Wiley & Sons, Inc.



Principles of Fracture Mechanics

- Fracture Mechanics; 재료 파괴 역학;
- 재료에 결함(flaw)이 존재함을 가정. 재료 성질, 가해진 응력의 크기, 균열을 초래할 수 있는 결함의 존재 및 균열 전파 기구 사이의 관계를 '정량화' 하는 학문
- 설계 엔지니어는 구조물이 파괴에 대해 얼마나 정량적인 저항력이 있는지 알아야 한다.
- 학부생으로써, 이미 정립이 되어있는 관계식들을 살펴보고, 이를 활용하는 법을 살피는데 주력하자.

Stress raiser 응력집중(인)자

- Fracture strength(파괴 강도; 즉 파괴가 일어나기 위해 필요한 응력)는 원자들간의 응집력과 관계있다.
 - 이론적 추정치: $\sim 0.1E$
 - 실험치: $0.01E \sim 0.0001E$
- 위와 같이 원자 응집력(혹은 원자 결합 에너지)을 바탕으로 예상한 fracture strength는 실험치와 큰 차이가 있다 - 이는 이론적 추정치에는 물질 내/외부의 flaw를 고려하지 않았기 때문이다.
- 실제로 이러한 microscopic flaw들의 주위에는 응력이 증폭 (amplified) 된다. 이러한 응력 증폭을 일으키는 voids, notches, surface scratches 등을 통틀어 stress-raiser 라고 부른다.

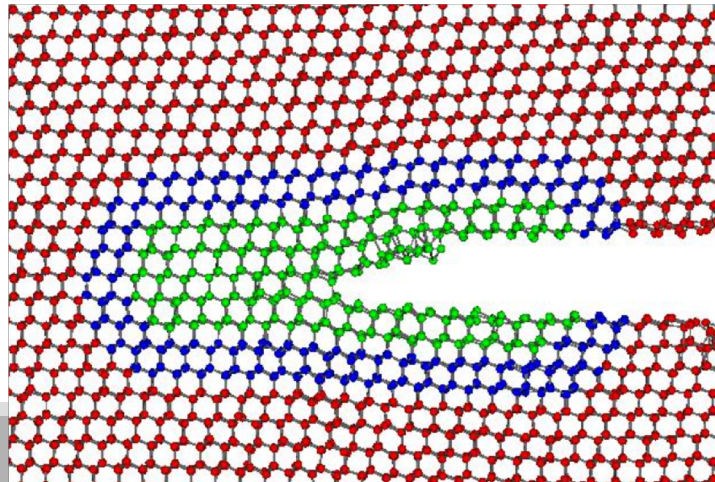

Stress concentration (응력 집중)

전술한바와 같이 응력은 void 등의 defect 주위에서 '증폭' 된다. 이를 '응력 집중'이라 하는데, 그 정량적 크기는 defect의 기하학적 특성(ex. Void의 방위, 크기, 모양)에 영향을 받는다.

St. Venant principle (생 베낭 원리)

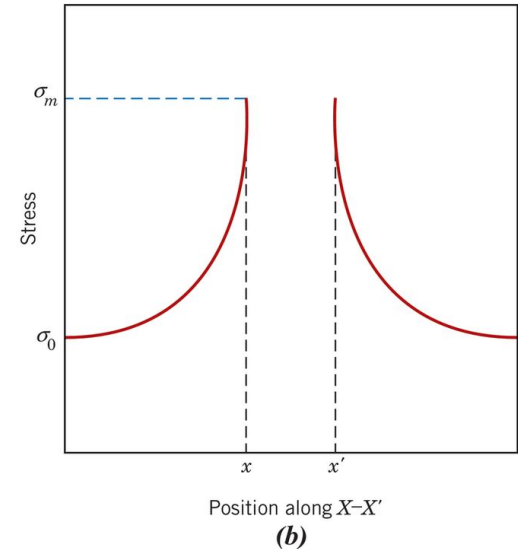
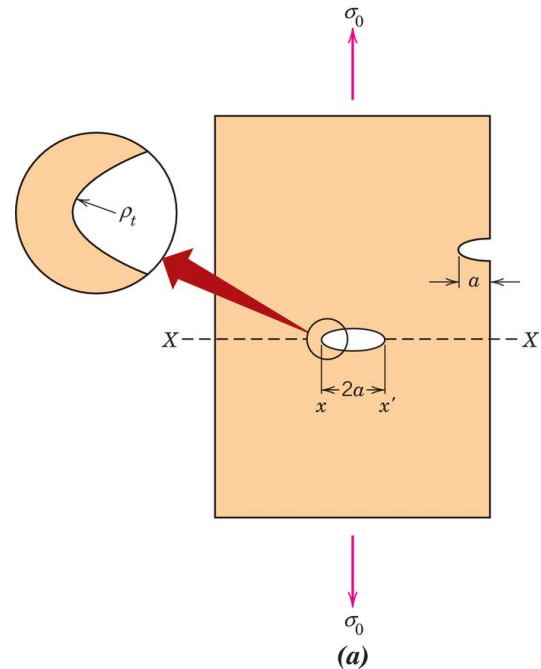

For a long crack oriented perpendicular to the applied stress, the maximum stress near the crack tip:

$$\sigma_m = 2\sigma_0 \left(\frac{a}{\rho_t}\right)^{0.5} \quad \text{where } \sigma_0: \text{(engineering) applied stress}$$

$$\sigma_m \propto a^{0.5}$$

a : 표면 균열 길이; half-length of crack (길수록 σ_m 상승)

$$\sigma_m \propto \left(\frac{1}{\rho_t}\right)^{0.5}$$

ρ_t : 균열 첨단부(tip)의 곡률반경(radius of curvature)

(곡률이 완만할 수록, 곡률 반경이 클수록 σ_m 감소)

Stress concentration factor

- 응력집중의 결과: $\sigma_m > \sigma_0$ thus $\frac{\sigma_m}{\sigma_0} \gg 1$
- 응력집중도(균열에 의해 외부의 응력이 집중되는 정도)를 응력 집중 계수(stress concentration factor K_t)로 표현하기도.
- $K_t = \frac{\sigma_m}{\sigma_0}$
- 앞서 소개된 Eq. 10.1을 통해 $K_t = 2 \left(\frac{a}{\rho_t}\right)^{0.5}$

Eq. 10.1

$$\sigma_m = 2\sigma_0 \left(\frac{a}{\rho_t}\right)^{0.5}$$

In ductile materials, plastic deformation at a crack tip “blunts” the crack.

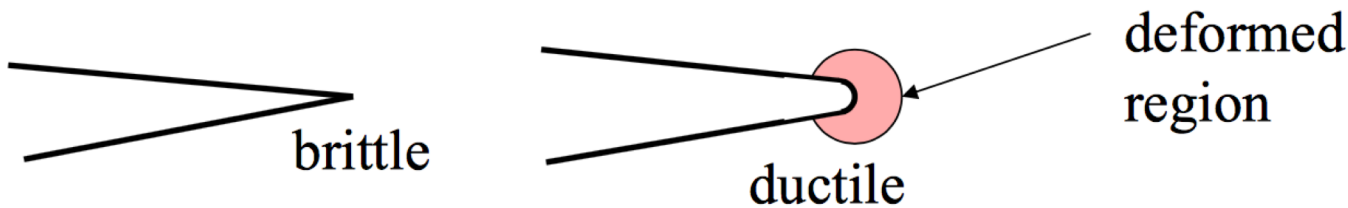

일반적으로 취성 재료가 응력상승에 더욱 취약하다. 연성 재료의 경우, σ_m 가 증가하다 σ^Y 에서 소성변형이 발생 (즉 crack tip 부근의 변형으로 인해 sharpness가 무뎠다)

언제 Crack이 전파되나?

- Elastic strain energy:
 - Energy is stored in material as it is elastically deformed (resilience를 생각해보자).
 - This energy is released (thus total energy is reduced), when the crack propagates (yes, the natural way)
 - When crack propagates, the number of atoms not fully connected with their neighbors increases. That means, the new 'surface' is created. Creation of incompletely connected atoms (surface) requires energy.

- Critical stress for crack propagation (with crack length being $2a$ – *internal* crack)

$$\sigma_c = \left(\frac{2E\gamma_s}{\pi a} \right)^{0.5} \quad (\text{Griffith's criterion; applicable for linear elastic materials})$$

where E : elastic modulus; γ_s : specific surface energy

- For ductile materials γ_s in the above is replaced by $\gamma_s + \gamma_p$ (γ_p : plastic deformation energy)
- Apply the above Eq. to Example 10.1

Two approaches in (LE) Fracture Mechanics

1. The energy criterion (에너지조건에 기반한 접근법)

- $E = \frac{\pi \sigma a^2}{\mathbb{E}}$
- Energy release rate (에너지 방출 속도)가 임계값을 가질 때 crack이 전진
- $E_c = \frac{\pi \sigma_c a_c^2}{\mathbb{E}}$ (σ_c : failure stress, a_c : critical crack size; E_c : critical energy release rate)

2. The stress intensity approach (응력집중 현상에 기반한 접근법)

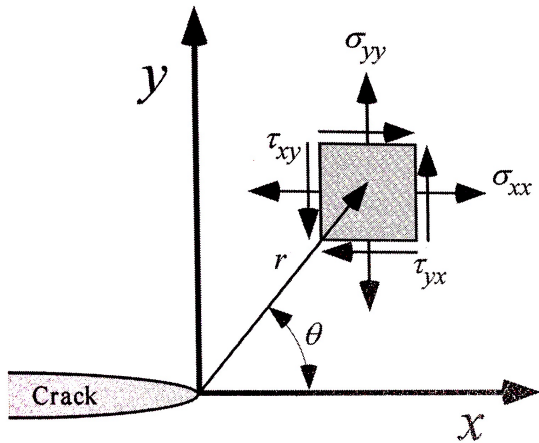

$$\sigma_{xx} = \frac{K_I}{\sqrt{2\pi r}} \cos\left(\frac{\theta}{2}\right) \left[1 - \sin\left(\frac{\theta}{2}\right) \sin\left(\frac{3\theta}{2}\right) \right]$$

$$\sigma_{yy} = \frac{K_I}{\sqrt{2\pi r}} \cos\left(\frac{\theta}{2}\right) \left[1 + \sin\left(\frac{\theta}{2}\right) \sin\left(\frac{3\theta}{2}\right) \right]$$

$$\tau_{xy} = \frac{K_I}{\sqrt{2\pi r}} \cos\left(\frac{\theta}{2}\right) \sin\left(\frac{\theta}{2}\right) \cos\left(\frac{3\theta}{2}\right)$$

- Plate 의 경우 $K_I = \sigma \sqrt{\pi a}$
- Failure는 K_I 값이 특정 임계값을 가질 때 발생: $K_I = K_{Ic}$

▪ E_c 와 K_{Ic} 는 재료의 failure에 대한 저항 정도를 나타낸다. 즉, toughness는 E_c 혹은 K_{Ic} 로 나타낼 수 있다.

▪ E 와 K_I 는 서로 관련있다 (LEFM): $E = \frac{K_I^2}{\mathbb{E}}$

Crack growth condition

- 균열 전파에 대한 임계 응력(σ_c)과 균열 길이의 관계가 'Stress Intensity Factor'로 설명된다.

$$K_c = Y\sigma_c\sqrt{\pi a}$$

Where K_c : 파괴 인성 (fracture toughness); 균열 존재시 취성 파괴에 대한 재료의 저항정도
Y: 균열 크기, 시편의 크기, 기하학적 형상, 하중 적용 방식 등에 의존하는 parameter

- For plates, or thin specimens, K_c depends on the thickness.

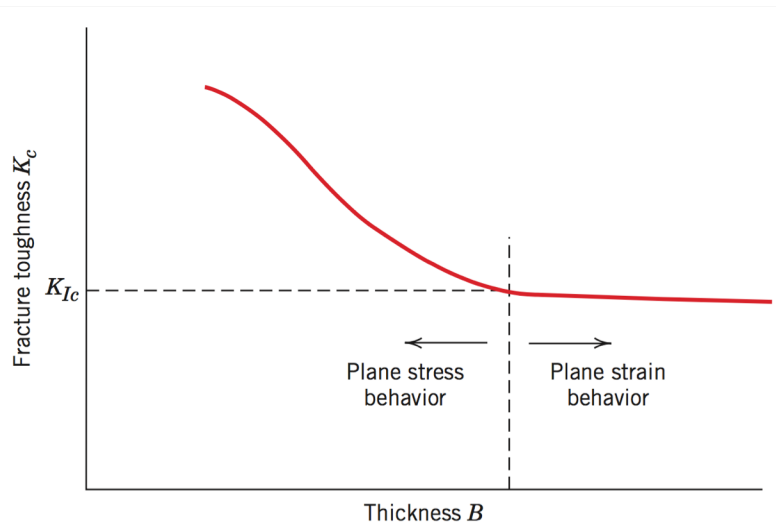

시편의 두께가 시편 전체 형상에 비해 충분히 두꺼울때, 평면 변형률 조건(plane-strain condition)을 이룬다. 이때의 K_c 값을 특별히 K_{Ic} (평면 변형률 파괴 인성)라 한다.

Subscript 'I'는 실제로 관련된 균열면 변위 형태를 이룬다 (그림 10.10 참고)

$$K_{Ic} = Y\sigma_c\sqrt{\pi a_c}$$

Plane-strain condition and Y value

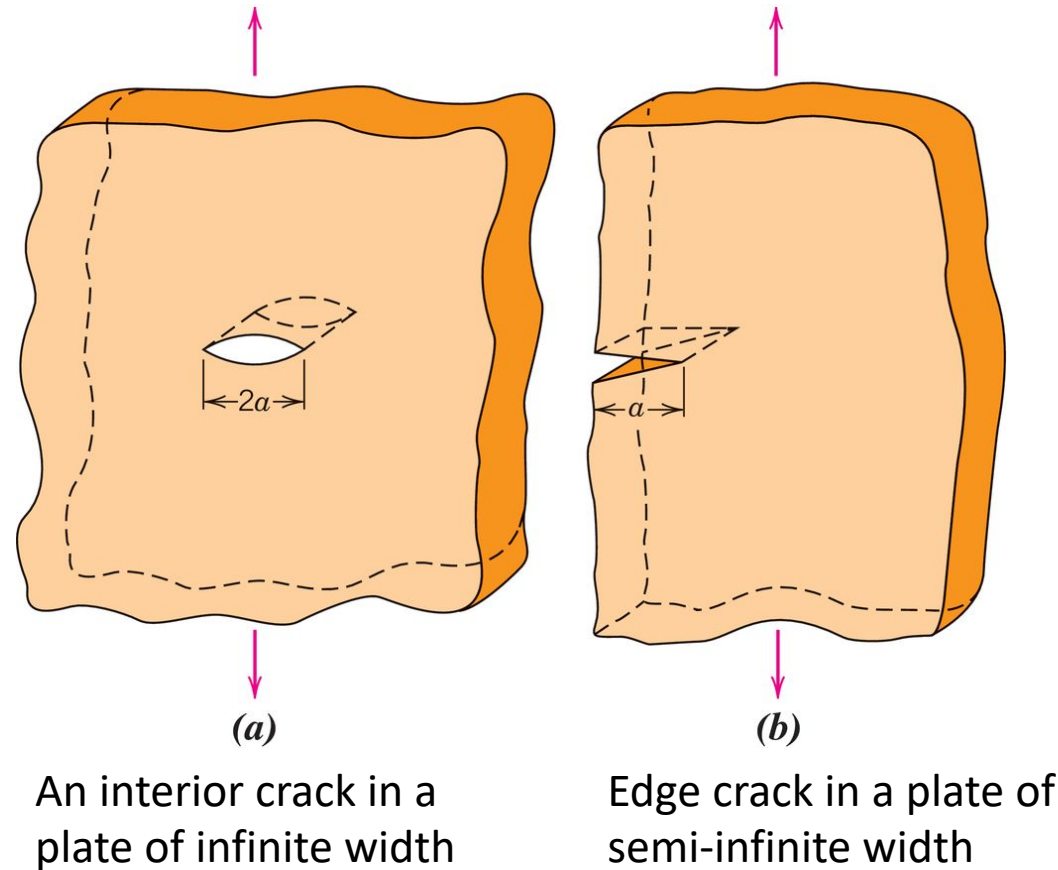

원편의 시편과 같이 충분히 두꺼운 재료에 in-plane uniaxial tension 상태를 가하면 두께방향으로 거의 strain이 없는 상태.

이를 plane-strain condition이라 한다.

K_c 가 형상학적 파라미터와 응력으로 표현된 간단한 함수형식이라면... (ex: $K_c = Y\sigma_c\sqrt{\pi a}$)
 Y 값은 균열 크기, 시편의 크기 및 기하학적 형상과 하중 적용 방식에 따라 달라진다.

(a) $Y=1$ (b) $Y \approx 1.1$

Y values under various conditions

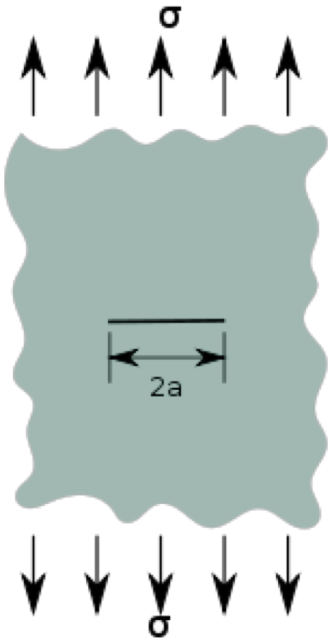

$$K_I = \sigma\sqrt{\pi a}$$

$$Y=1$$

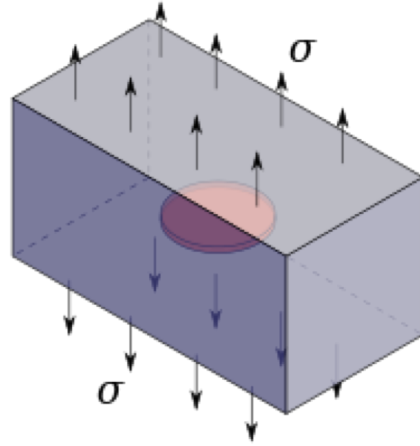

$$K_I = 2\sigma\sqrt{a/\pi} = \left(\frac{2}{\pi}\right)\sigma\sqrt{\pi a}$$

$$Y = \left(\frac{2}{\pi}\right)$$

복잡한형상, 복잡한 경계조건

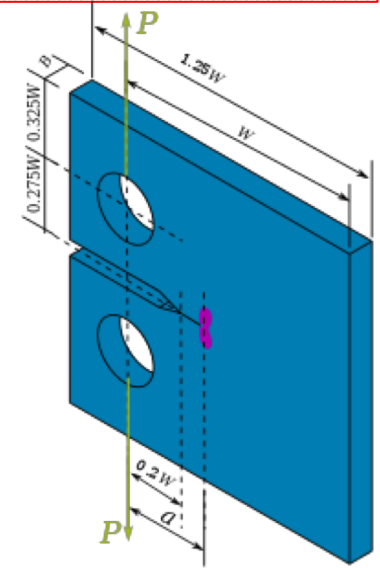

$$K_I = \frac{P}{B}\sqrt{\frac{\pi}{W}}\left[16.7\left(\frac{a}{W}\right)^{\frac{1}{2}} - 104.7\left(\frac{a}{W}\right)^{\frac{3}{2}} + 369.9\left(\frac{a}{W}\right)^{\frac{5}{2}} \dots\right]$$

Y 값이 간단하게 나타나지 않는다.

Fracture Toughness Ranges

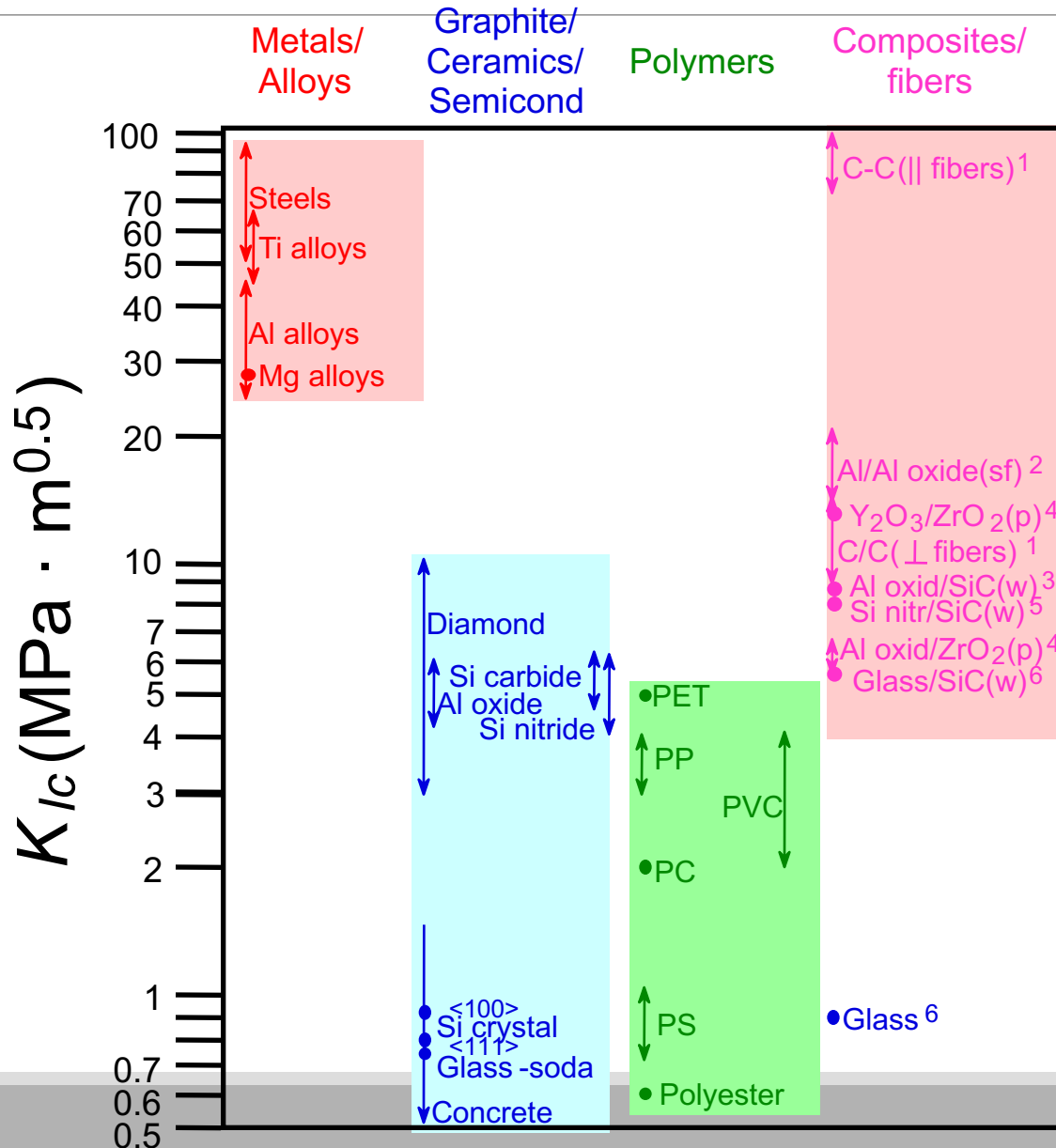

Based on data in Table B.5,
Callister & Rethwisch 9e.

Composite reinforcement geometry is: f = fibers; sf = short fibers; w = whiskers; p = particles. Addition data as noted (vol. fraction of reinforcement):

- (55vol%) *ASM Handbook*, Vol. 21, ASM Int., Materials Park, OH (2001) p. 606.
- (55 vol%) Courtesy J. Cornie, MMC, Inc., Waltham, MA.
- (30 vol%) P.F. Becher et al., *Fracture Mechanics of Ceramics*, Vol. 7, Plenum Press (1986). pp. 61-73.
- Courtesy CoorsTek, Golden, CO.
- (30 vol%) S.T. Buljan et al., "Development of Ceramic Matrix Composites for Application in Technology for Advanced Engines Program", ORNL/Sub/85-22011/2, ORNL, 1992.
- (20vol%) F.D. Gace et al., *Ceram. Eng. Sci. Proc.*, Vol. 7 (1986) pp. 978-82.

Crack surface displacement modes

Mode I

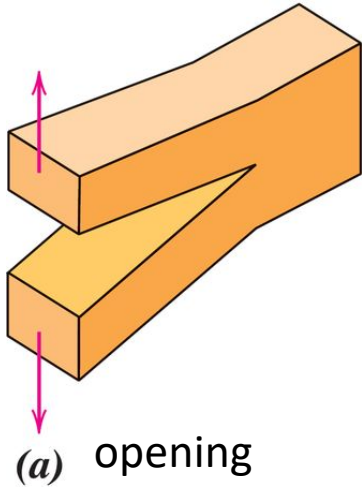

Mode II

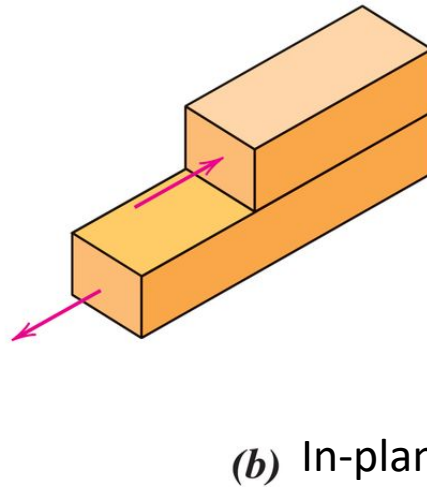

Mode III

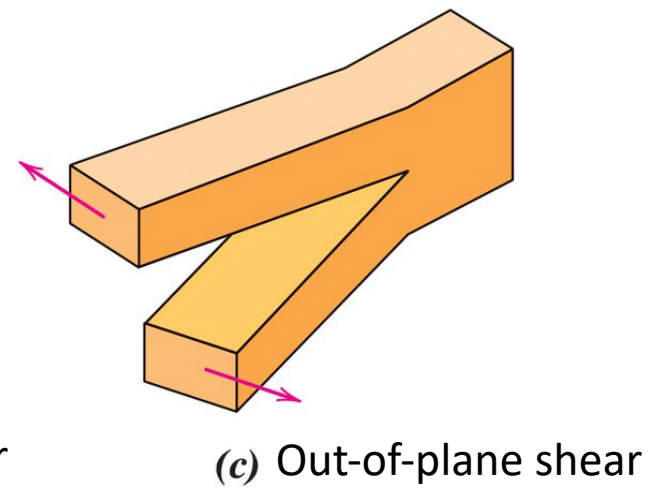

The three modes of crack surface (균열 표면) displacement (변위).

파괴 역학을 이용한 설계

- 구조물의 파괴 가능성을 진단/검사 하기 위해서는 앞서 살펴본 파괴 인성 파라미터를 이용할 수 있다.
 - $K_{Ic} = Y\sigma_c\sqrt{\pi a_c}$ (평면 변형률 조건에서의 파괴 인성)
- 주어진 구조물과 기대되는 응력상태로 인해 Y 값이 알려져 있다면 파괴 인성(K_{Ic})은 파괴가 발생할 때 구조물에 가해진 응력(σ_c), 균열 길이(a_c)와 관련있다. 이 세 파라미터들 중, 실제 적용에 제약을 받는지, 혹은 설계 통제를 받을지를 결정할 수 있어야 한다. 세 파라미터들 중 두 개가 정해지면 나머지는 위의 공식을 통해 구할 수 있다.
- 예를 들어 만들고자 하는 구조물의 파괴는 구조물에 기대되는 응력과 구조물의 재료내의 균열 길이를 통해 예상할 수 있다.

파괴 역학 (LEFM) 고려한 design?

$$K = Y\sigma\sqrt{\pi a}$$

한가지 재료로 만들어진
구조물에 파괴를 일으킬만한
응력 조건을 알고 있다.

그럴때, 구조물의 toughness를 K_c 라
한다면, 해당 구조물의 K 값을 위 식을 통해
구해 $K < K_c$ 를 만족해야 안전.

혹은 $K \leq p K_c$ 여기서 p 는 1보다 작은 값

Y 가 상수라면 K 는 외력의 세기(σ 혹은 하중)와 균열의 크기 (a)에 의해 결정된다.
따라서, 이때 파괴 조건은 두 변수에 의해 결정(determine)된다.

만약 하중이 fix 라면 허용되는 균열의 크기가 있을테고,
균열의 크기가 fix라면 허용되는 최대 하중이 있을 것이다.

Design Against Crack Growth

- Crack growth condition:

$$K \geq K_c = Y\sigma\sqrt{\pi a}$$

- **Largest**, most highly **stressed** cracks grow first!

- 결함의 크기와 파괴 인성을 알 때, 허용되는 design stress의 범위를 아래와 같이 표현

$$\sigma_{design} < \frac{K_c}{Y\sqrt{\pi a_{max}}}$$

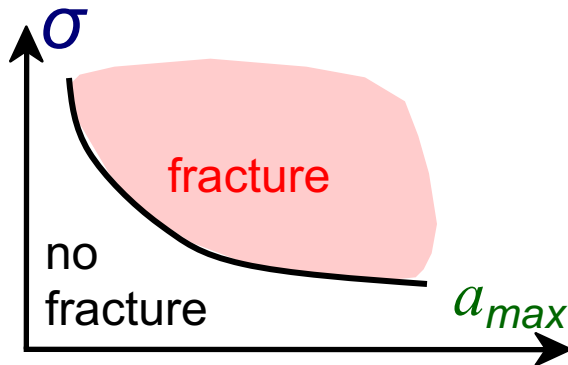

- 구조물의 허용되는(예상되는) design stress와 파괴 인성을 알 때, 허용되는 결함의 크기를 표현 아래와 같이 표현가능.

$$a_{max} < \frac{1}{\pi} \left(\frac{K_c}{Y\sigma_{design}} \right)^2$$

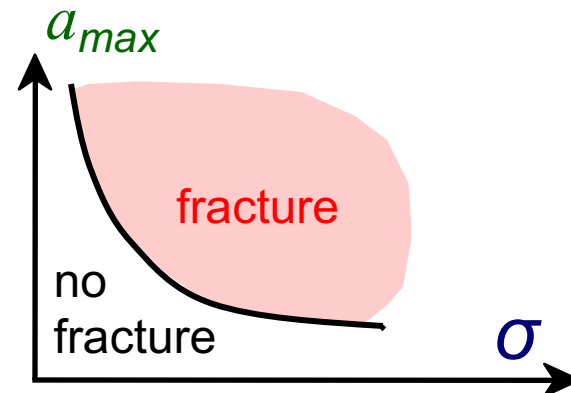

Example 10.1(a)

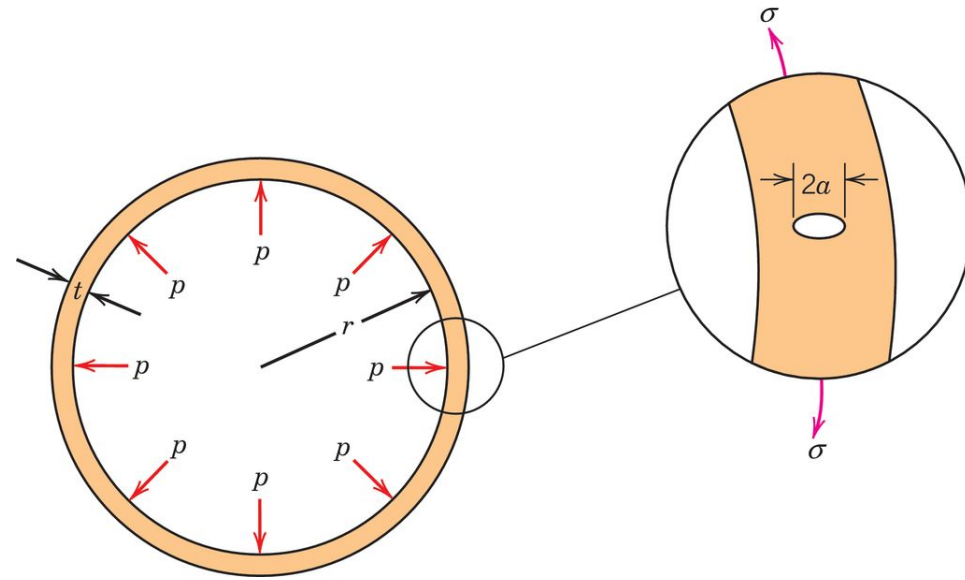

벽의 두께가 t , 반지름이 r 인 구형 (sphere)의 내부에 p 압력이 존재. 이로 인해, 파이프의 원주방향으로 σ 만큼의 인장력이 가해지고 있다.

해당 조건에서 plane-strain condition을 가정 – Eq. 10.5 혹은 Eq. 10.6 Eq. 10.7

설계조건 1: 해당 탱크의 균열이 생성되어 파손이 빠르게 진전되기 전에 항복이 일어나도록 설계한다. 항복이 발생하면 급격한 파손이 일어나기 전에 소성 변형이 일어나 탱크 내부의 압력을 어느정도 낮춰주는 효과 (소성변형으로 탱크모양 변화->탱크내부 부피 증가). 주어진 조건에서 제시하는 설계조건을 따라 항복을 발생을 유발하려면 어떤 재료를 사용해야 할까?

결과적으로 파괴가 발생할때의 균열크기 (a_c)가 커야된다 – Eq. 10.7사용; Y 는 고정

$$a_c = \frac{1}{\pi} \left(\frac{K_{Ic}}{\sigma Y} \right)^2 = \frac{1}{\pi Y^2} \left(\frac{K_{Ic}}{\sigma} \right)^2$$

따라서 해당 설계법에 따르면 $\frac{K_{Ic}}{\sigma}$ 값이 작은 재료가 선호된다.

Example 10.1(b)

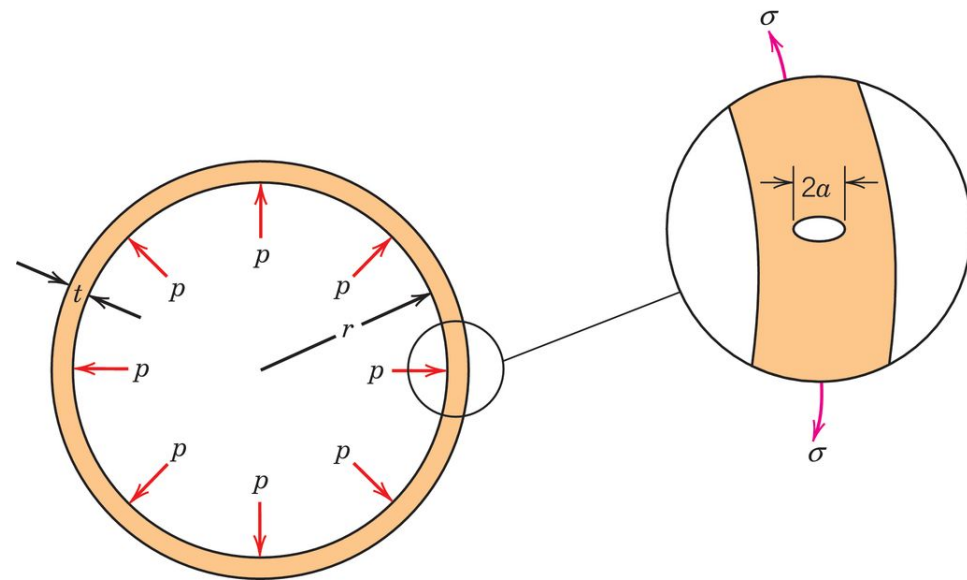

결과적으로 균열크기의 크기가 t 와 같을 때 해당 조건을 만족한다. 이를 Eq. 10.5 대입하면

$$K_{Ic} = Y\sigma\sqrt{\pi t} \quad \text{Eq. (a)}$$

해당 구형 압력 탱크의 작용 응력(σ)은 탱크내의 압력 (p), 반지름(r), 두께(t)와 연관되어있다.

$$\sigma = \frac{pr}{2t} \quad \text{Eq. (b)}$$

그리고 해당 설계조건상에서 탱크는 항복이 일어나지 않아야 하므로, 응력을 항복 강도로 치환하여 $\sigma_Y = \frac{pr}{2t}$,

$$\text{즉 } t = \frac{pr}{2\sigma_Y}$$

해당 식을 Eq. (a)에 대입하여 정리하면

$$K_{Ic} = Y\sigma_Y \sqrt{\frac{\pi pr}{2\sigma_Y}} = Y \sqrt{\frac{\pi pr\sigma_Y}{2}} \rightarrow \left(\frac{K_{Ic}}{Y}\right)^2 = \frac{\pi pr\sigma_Y}{2}$$

이를 압력에 대해 정리하면

$$p = 2 \left(\frac{K_{Ic}}{Y}\right)^2 / (\pi r\sigma_Y)$$

다시 정리하자면

$$p = \left(\frac{K_{Ic}^2}{\sigma_Y}\right) \frac{2}{\pi r Y}$$

r, Y 등은 변수가 아니므로, $\frac{K_{Ic}^2}{\sigma_Y}$ 값이 높을 수록 견딜 수 있는 압력이 커진다.

설계조건 2: 우리가 살펴볼 또 다른 설계 조건은, 파단전 누설 (leak-before-break) 원리를 따른다. 파이프의 전체 구조물이 break가 될만큼의 빠른 균열 성장이 일어나기 전에 용기 벽 두께를 조절하여 균열 성장에 대한 여유를 준다. 균열이 매우 작으면 안정. 역설적이게도 하나의 균열이 벽의 두께와 동일한 길이를 가진다면 해당 부위에 균열 전파로 인해 탱크에 '구멍' -> 탱크 전체가 파손이 되지 않고 leak -> 내부 압력 감소 효과 및 catastrophic failure 방지; 이를 통해 최대 허용되는 탱크내의 압력값(p)을 구해보자.

예제: Aircraft Wing

- Material has $K_{Ic} = 26 \text{ [MPa} \cdot \text{m}^{1/2}]$
- Two designs to consider...

Design A

- largest flaw is 9 mm
- failure stress = 112 MPa

Design B

- use same material
- largest flaw is 4 mm
- failure stress = ?

- Use...

$$\sigma_c = \frac{K_{Ic}}{Y \sqrt{\pi a_{\max}}}$$

- Key point: Y and K_{Ic} are the same for both designs (same material, same geometry, same type of stress).

$$\frac{K_{Ic}}{Y \sqrt{\pi}} = \sigma \sqrt{a} = \text{constant}$$

--Result:

$$\left(\overset{112 \text{ MPa}}{\sigma_c} \sqrt{\overset{9 \text{ mm}}{a_{\max}}} \right)_A = \left(\sigma_c \sqrt{\overset{4 \text{ mm}}{a_{\max}}} \right)_B$$

$$\text{Answer: } (\sigma_c)_B = 168 \text{ MPa}$$

Impact Testing: K_{IC} 의 정성적(qualitative) 측정

- Impact loading:
 - severe testing case
 - makes material more brittle
 - decreases toughness

Fig. 10.12(b), Callister & Rethwisch 9e.
(Adapted from H.W. Hayden, W.G. Moffatt, and J. Wulff, *The Structure and Properties of Materials*, Vol. III, *Mechanical Behavior*, John Wiley and Sons, Inc. (1965) p. 13.)

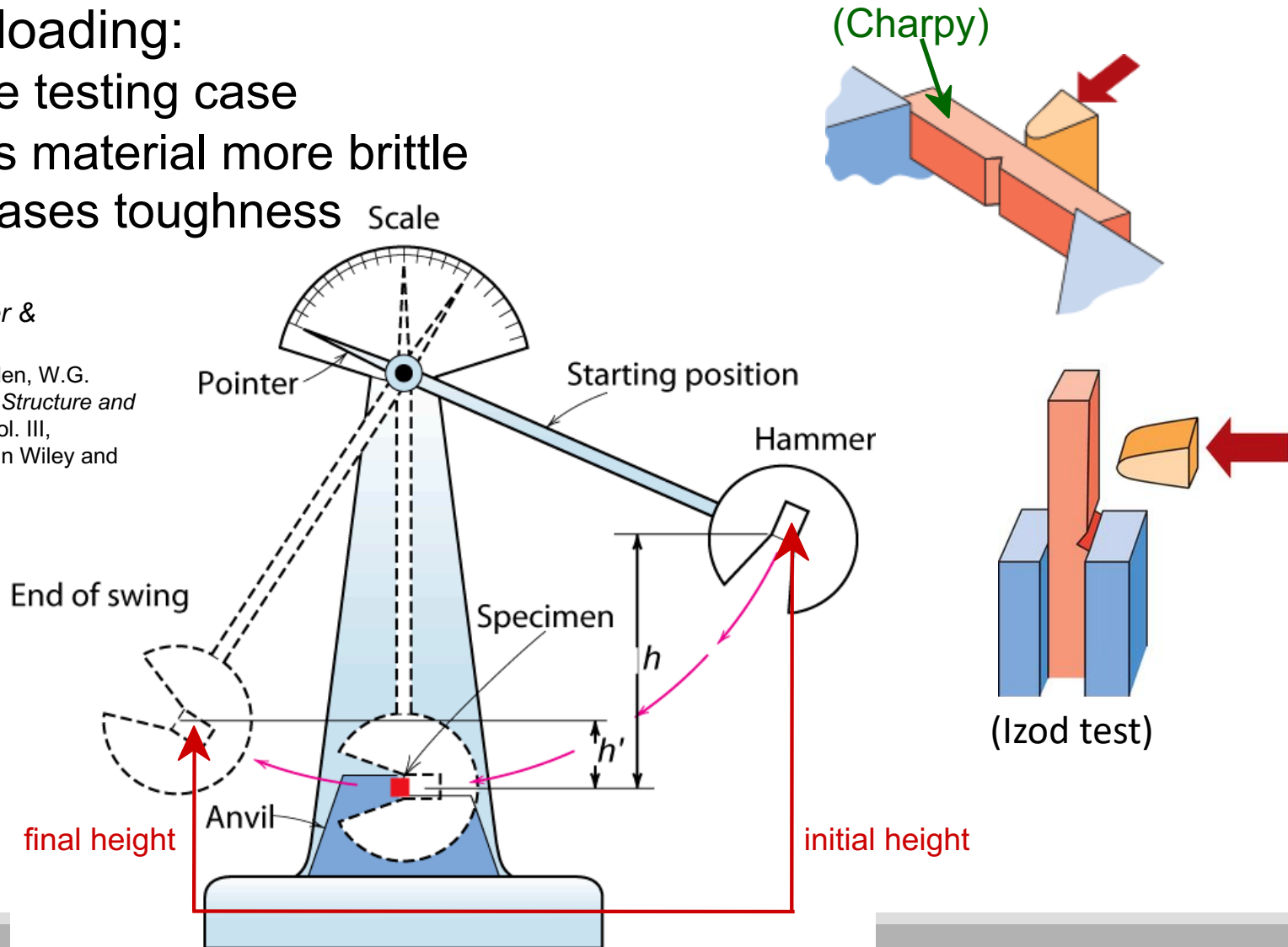

Influence of Temperature on Impact Energy

- Ductile-to-Brittle Transition Temperature (DBTT)...

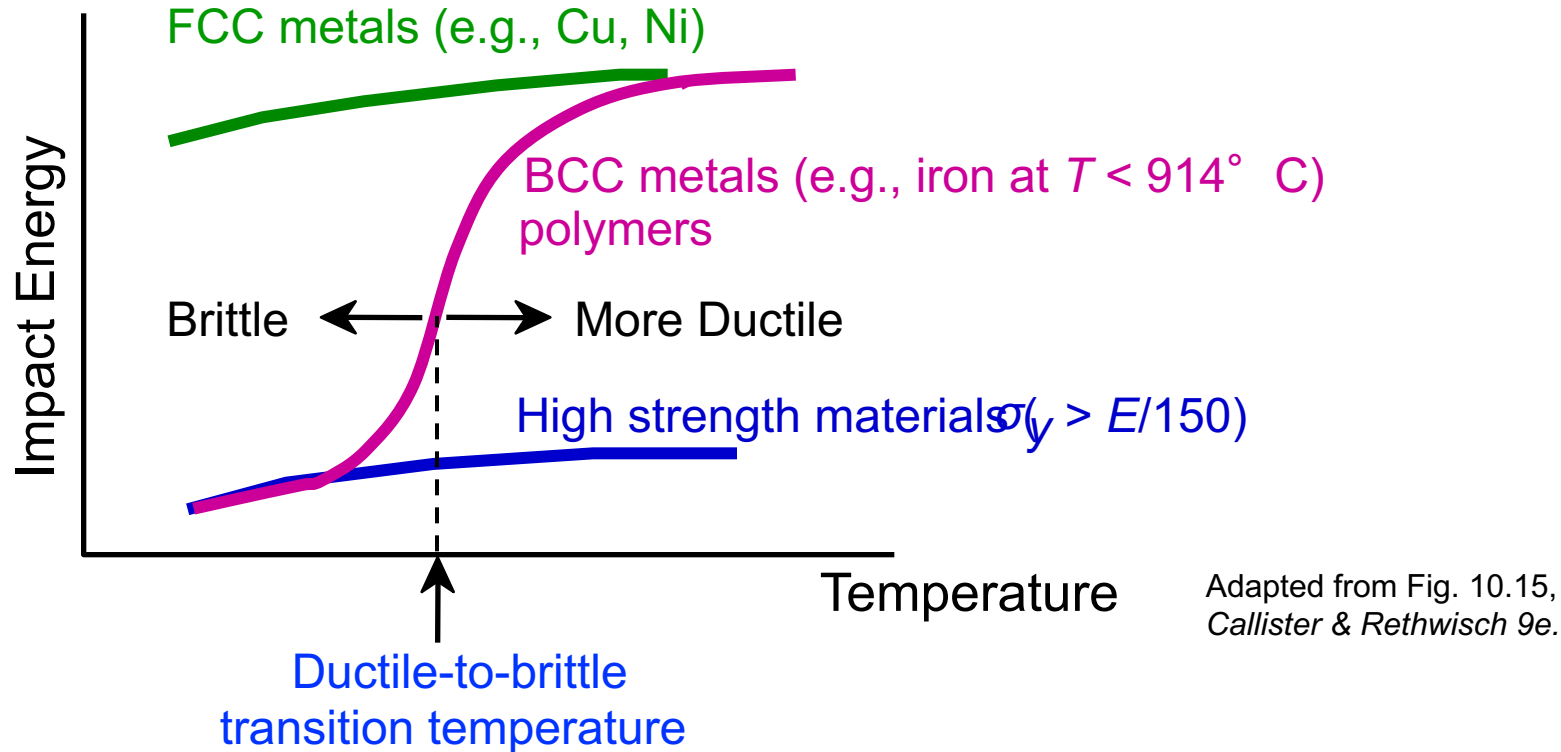

Main application of Charpy/Izod tests: to see if DBT happens.
You can tell at which temp the brittle fracture would occur.

CVN and DBTT

CVN: Charpy + V-Notch – 즉 V 모양의 notch가 있는 시편 대상의 Charpy 실험

-59 -12 4 16 24 79

—————> 실험 온도

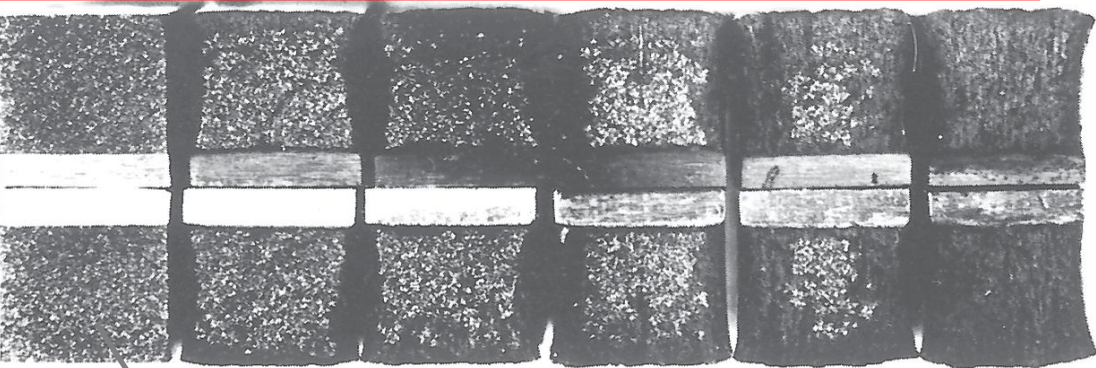

From R. W. Hertzberg, Deformation and Fracture Mechanics of Engineering Materials, 3rd edition, Fig. 9.6, p. 329. Copyright © 1989 by John Wiley & Sons, Inc., New York. Reprinted by permission of John Wiley & Sons, Inc.

온도에 따른 파단면의 변화

Grainy; faceted texture
(Brittle fracture의 특징)

섬유질 모양, 어두운 색;
이 두가지 성질은 모두
ductile fracture의 특성

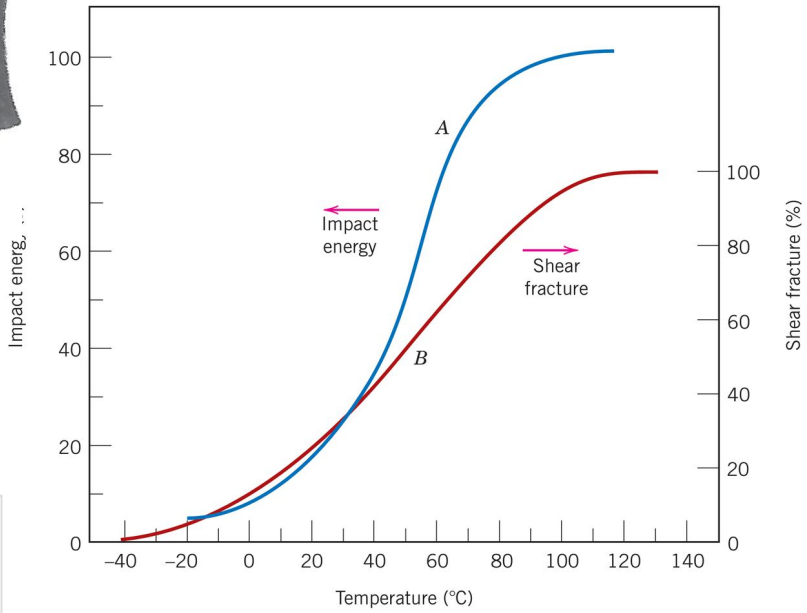

Reprinted from Welding Journal. Used by permission of the American Welding Society.

Factors affecting DBTT

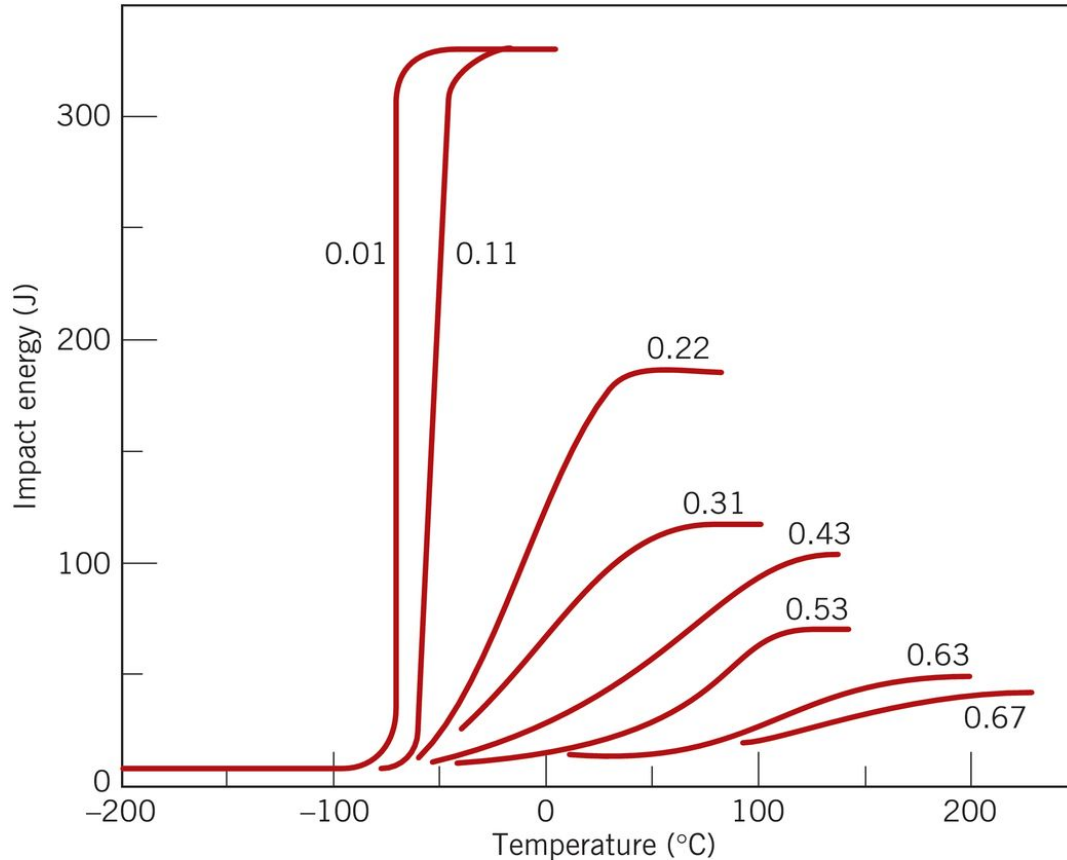

- Alloying contents
- Microstructure (grain size)

Reprinted with permission from ASM International, Materials Park, OH 44073-9989, USA; J. A. Reinbolt and W. J. Harris, Jr., "Effect of Alloying Elements on Notch Toughness of Pearlitic Steels," Transactions of ASM, Vol. 43, 1951.

Design Strategy: Stay Above The DBTT!

- **Pre-WWII: The Titanic**



Reprinted w/ permission from R.W. Hertzberg, "Deformation and Fracture Mechanics of Engineering Materials", (4th ed.) Fig. 7.1(a), p. 262, John Wiley and Sons, Inc., 1996. (Orig. source: Dr. Robert D. Ballard, *The Discovery of the Titanic*.)

- **WWII: Liberty ships**

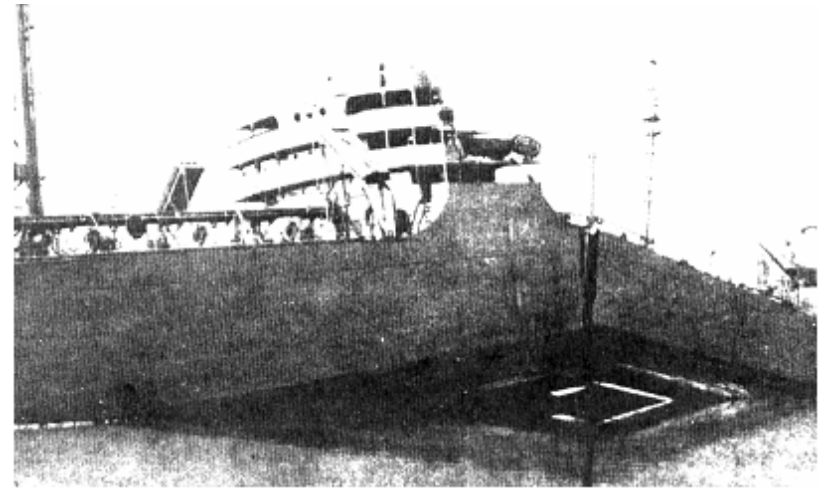

Reprinted w/ permission from R.W. Hertzberg, "Deformation and Fracture Mechanics of Engineering Materials", (4th ed.) Fig. 7.1(b), p. 262, John Wiley and Sons, Inc., 1996. (Orig. source: Earl R. Parker, "Behavior of Engineering Structures", Nat. Acad. Sci., Nat. Res. Council, John Wiley and Sons, Inc., NY, 1957.)

- **Problem: Steels (in BCC) were used having DBTT' s just below room temperature.**

DBTT & Feynman & Challenger

- On January 28, 1986, the Space Shuttle Challenger broke apart 73 seconds into its flight, leading to the deaths of its seven crew members.

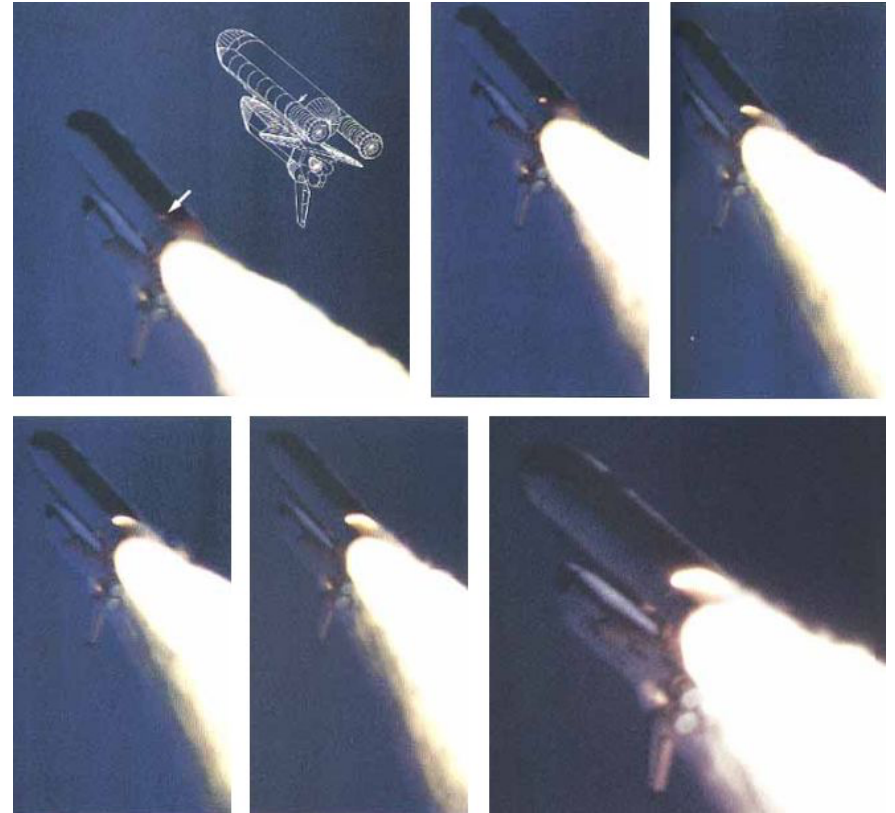

Fatigue (피로)

- 항복 강도나 인장강도보다 '매우' 낮은 응력상태에 발생하는 파손. 일반적으로 '반복'되는 응력 (혹은 변형률) 사이클에 의해 발생하는 파괴.
- 예: 교량 (bridge) – 자동차의 무게가 교량 구조물의 항복 강도나 인장강도에 비해 매우 낮으나, 반복적으로 되풀이 되어 파괴까지 이를 수 있다.
- 높은 응력상태가 아니므로, 소성변형이 거의 발생하지 않고, 그 특징도 전술한 brittle fracture와 유사.
- 주로 두 단계로 진행되어 최종 파손까지
 - 균열의 생성 (crack initiation)
 - 균열의 전파 (crack propagation)
 - 최종 파손 (final failure)

Fatigue and stress cycle

- **Fatigue** = failure under applied cyclic stress.
- The types of cyclic stress expected for Fatigue:
 - tension-compression
 - bending – unbending
 - twisting – untwisting
- Types of stress-time modes

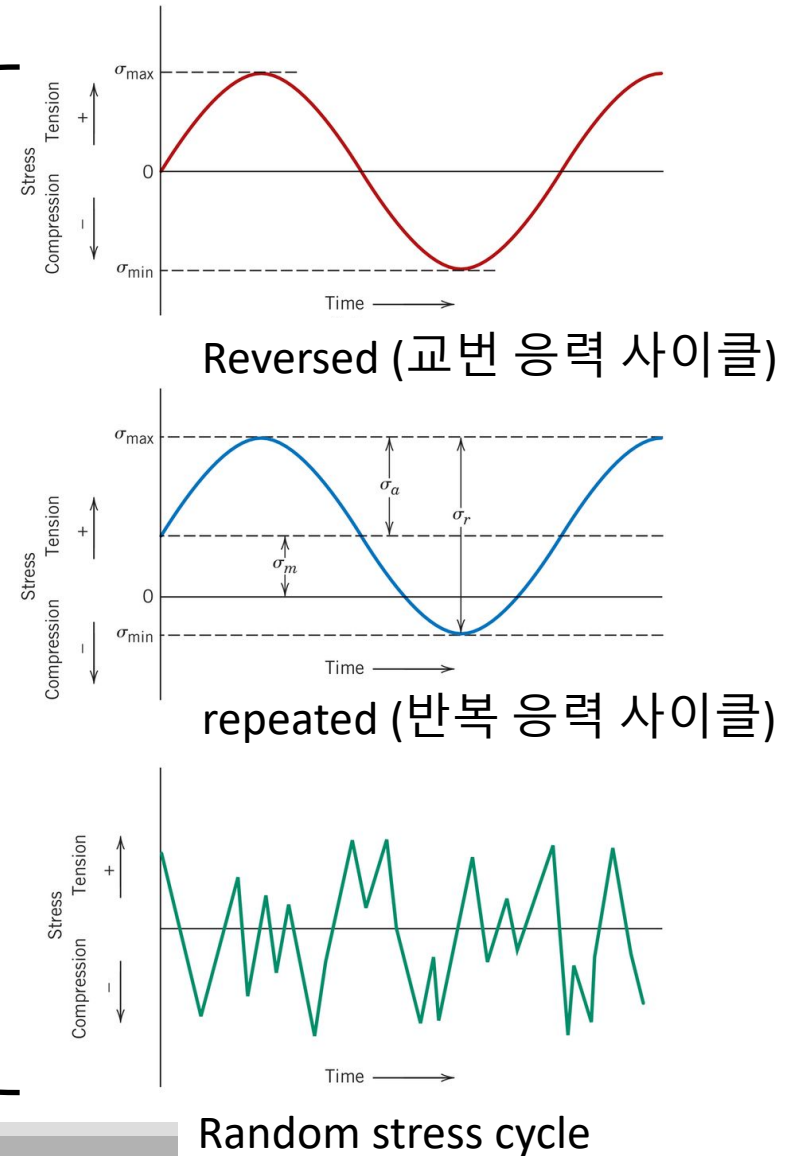

Parameterization of stress cycles

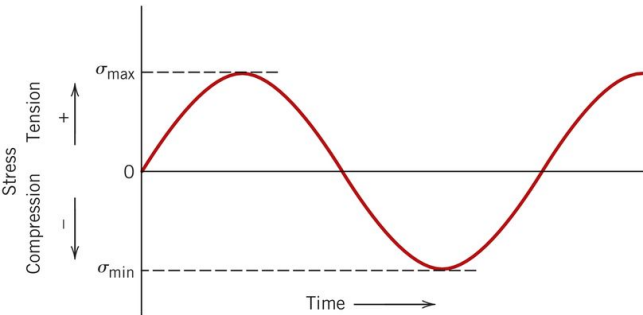

Reversed (교번 응력 사이클)

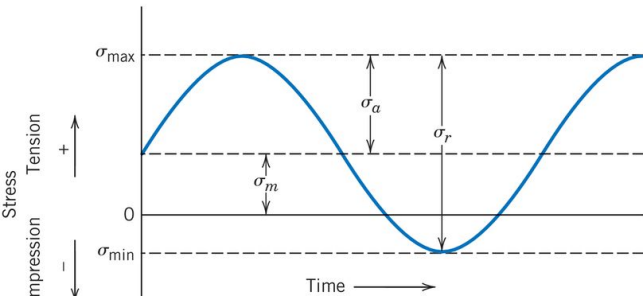

repeated (반복 응력 사이클)

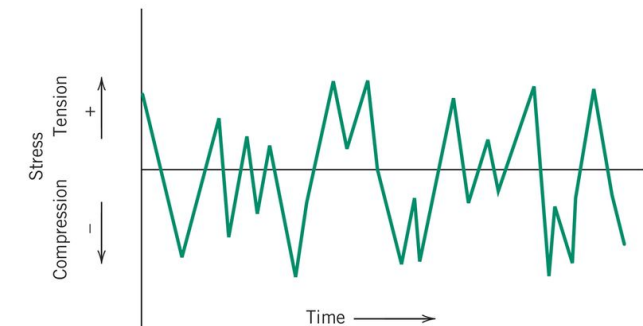

Random stress cycle

■ 응력 사이클을 매개변수화 - 즉 적은 개수/종류의 간단한 parameter를 통해서 표현해내는 방식으로 응력 사이클을 나타내기도 한다.

- $\sigma_{mean} = \frac{\sigma_{max} + \sigma_{min}}{2}$
- $\sigma_{range} = \sigma_{max} - \sigma_{min}$
- $\sigma_{amplitude} = \frac{\sigma_{range}}{2} = \frac{\sigma_{max} - \sigma_{min}}{2}$
- Stress ratio (R) = $\frac{\sigma_{min}}{\sigma_{max}}$

A typical fatigue test

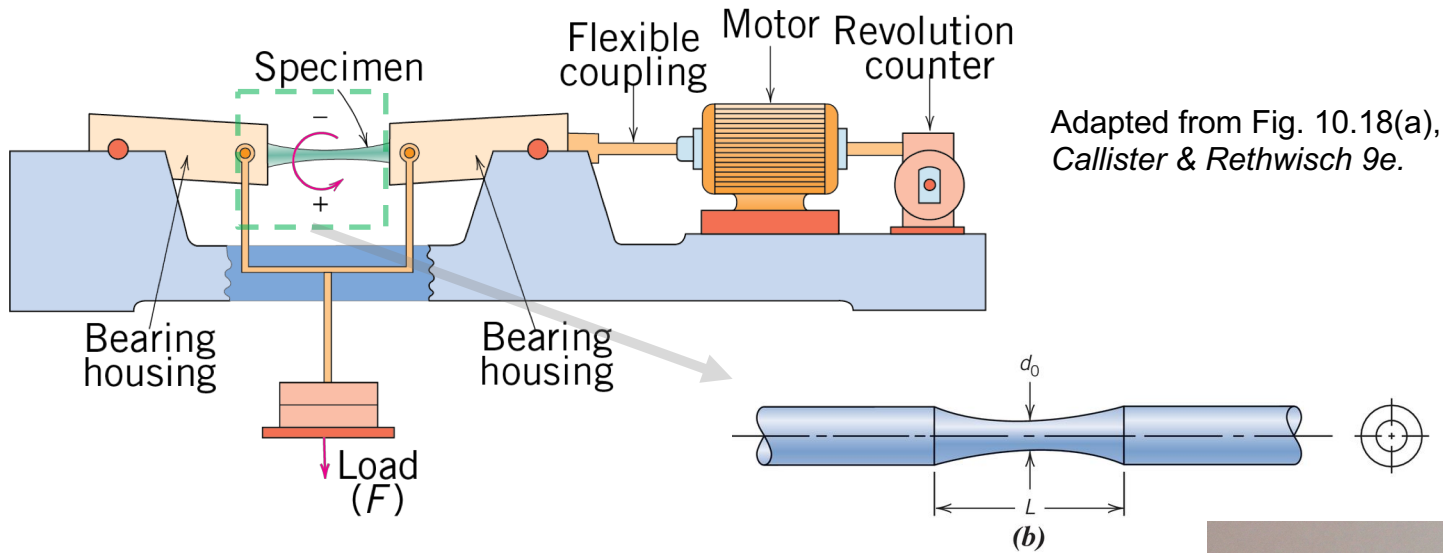

An example where the stress cycle is realized in combination of 'rotation' and 'bending'.

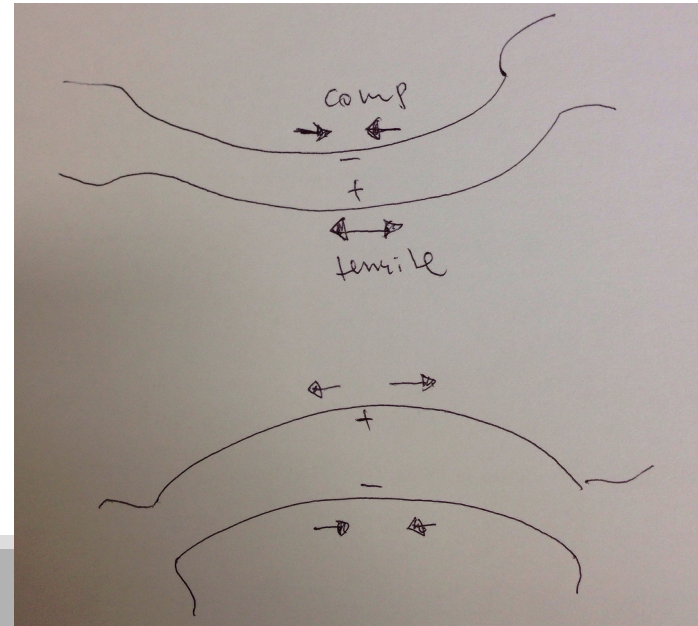

S-N curve 측정

- 응력 진폭(S)과 파손이 될 때 까지의 cycle 수(N)를 각각 y축 x축 으로 나타낸다.
- 응력 진폭을 바꾸면서 실험을 반복.
- Cycle수는 주로 log scale로 표시한다.

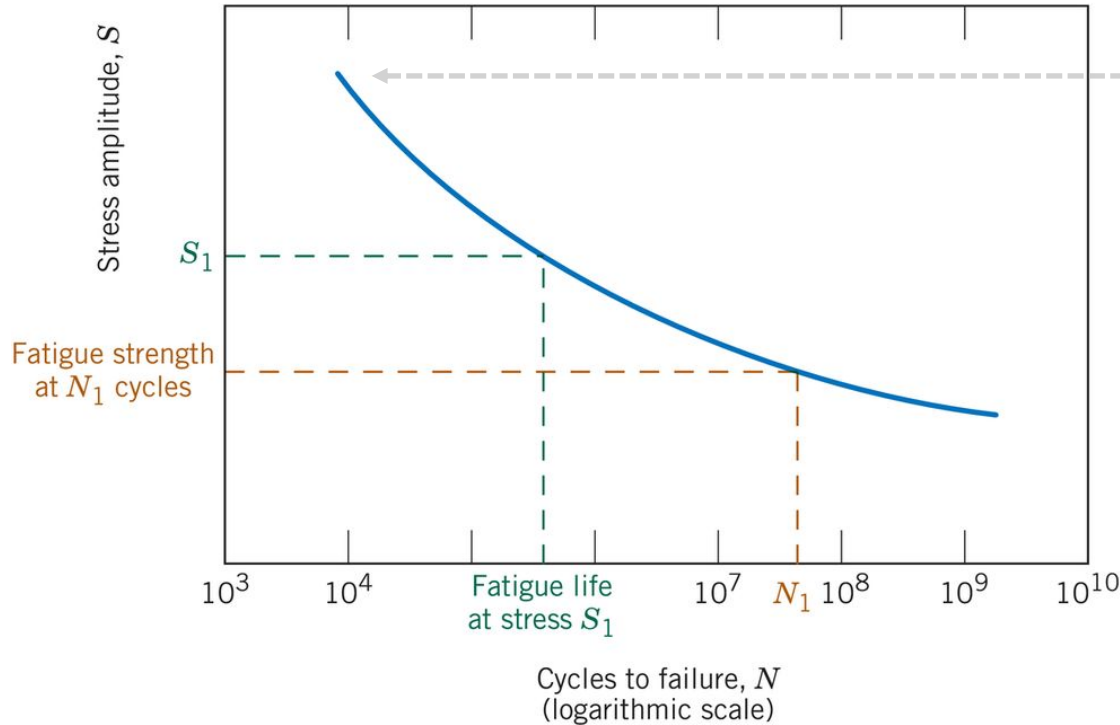

대개 TS의 2/3을 $\sigma_{\text{amplitude}}$ 로 설정한 실험부터 시작

점점 낮은 $\sigma_{\text{amplitude}}$ 값을 설정후 실험을 반복

Low-cycle fatigue

High-cycle fatigue

Types of Fatigue Behavior

- **Fatigue limit**
(endurance limit), S_{fat} :
--no fatigue if $S < S_{fat}$

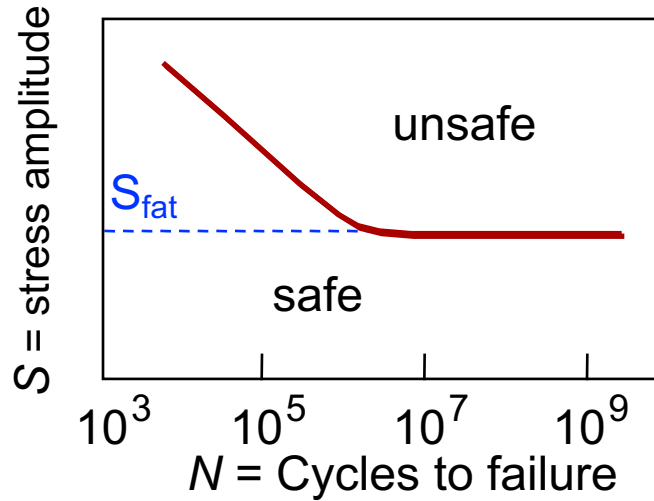

case for
Steel, Ti alloys ...

Adapted from Fig.
10.19(a), Callister &
Rethwisch 9e.

- For some materials,
there is no fatigue
limit!

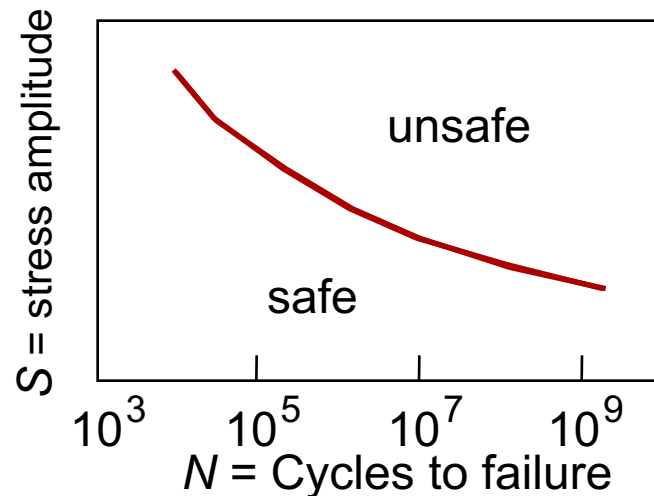

case for
Al, Cu, Mg...

Adapted from Fig.
10.19(b), Callister &
Rethwisch 9e.

S-N curves for various materials

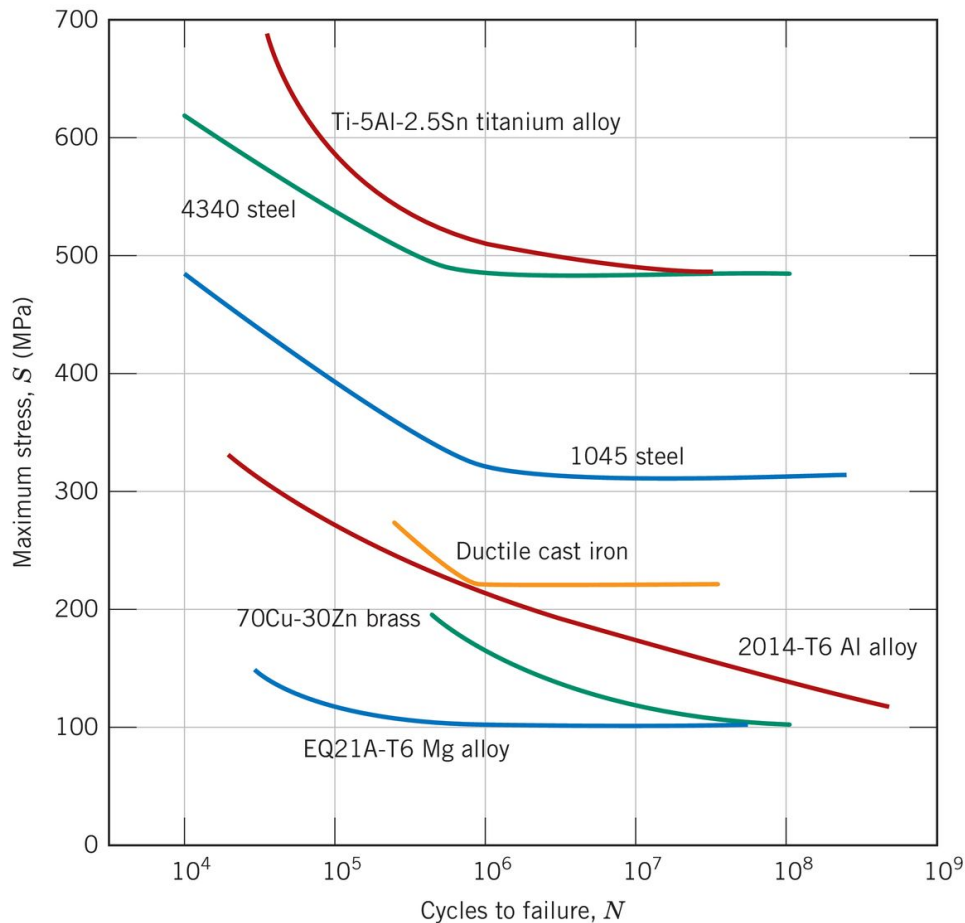

- 교번 응력 실험으로 얻어진 다양한 금속 재료의 S-N 곡선
- Fatigue limit을 보여주는 재료를 찾아보자.

예제 10.2 와 10.3

Data taken from the following sources and reproduced with permission of ASM International, Materials Park, OH, 44073: ASM Handbook, Vol. 1, Properties and Selection: Irons, Steels, and High-Performance Alloys, 1990; ASM Handbook, Vol. 2, Properties and Selection: Nonferrous Alloys and Special-Purpose Materials, 1990; G. M. Sinclair and W. J. Craig, "Influence of Grain Size on Work Hardening and Fatigue Characteristics of Alpha Brass," Transactions of ASM, Vol. 44, 1952.

Fatigue S-N probability

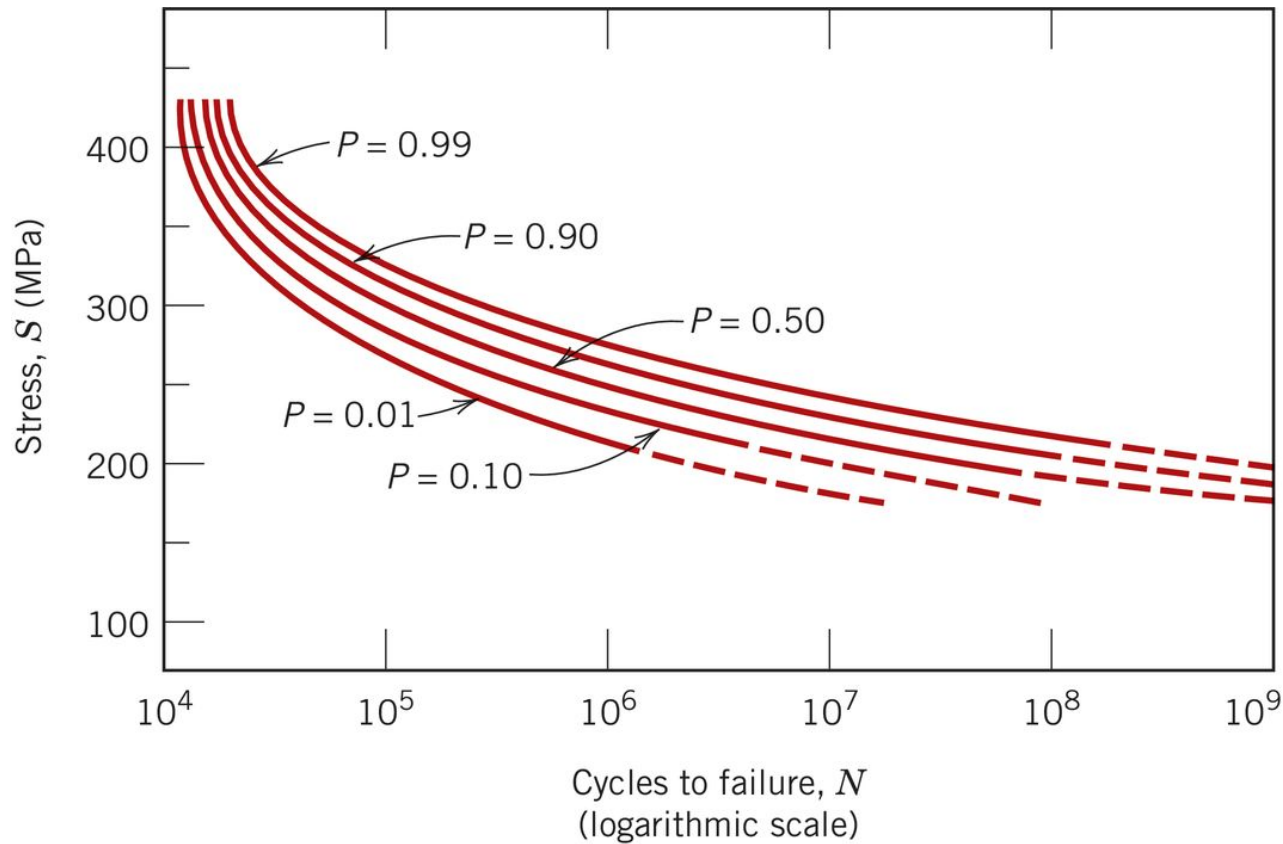

From G. M. Sinclair and T. J. Dolan, Trans. ASME, 75, 1953, p. 867. Reprinted with permission of the American Society of Mechanical Engineers.

Fatigue failure: initiation and propagation

- 1) Crack initiation (균열 생성)
 - Small crack is created where the stress is 'concentrated'.
- 2) Crack propagation (균열 전파)
 - Crack advances incrementally with each stress cycle
- 3) Final failure
 - When crack reaches the 'critical' size, failure rapidly occurs
- Cyclic loading can produce 'steps' caused by dislocation slip.
- $N_{\text{failure}} = N_{\text{crack initiation}} + N_{\text{crack propagation}}$
- For high cycle fatigue (low loads); $N_{\text{crack initiation}}$ is high.
- With increasing loads, $N_{\text{crack initiation}}$ decreases while $N_{\text{crack propagation}}$ increases.

Fatigue failure: initiation and propagation

- Crack initiation at the sites of stress concentration (microcracks, scratches, indents, dislocation slip steps and the like). Surface defect provides stress concentration thus surface quality is important.
- Crack propagation
 - Stage I: initial slow propagation along crystal planes with high resolved shear stress.
 - Stage II: Faster propagation perpendicular to the applied stress (i.e., typical feature observed for brittle fracture)

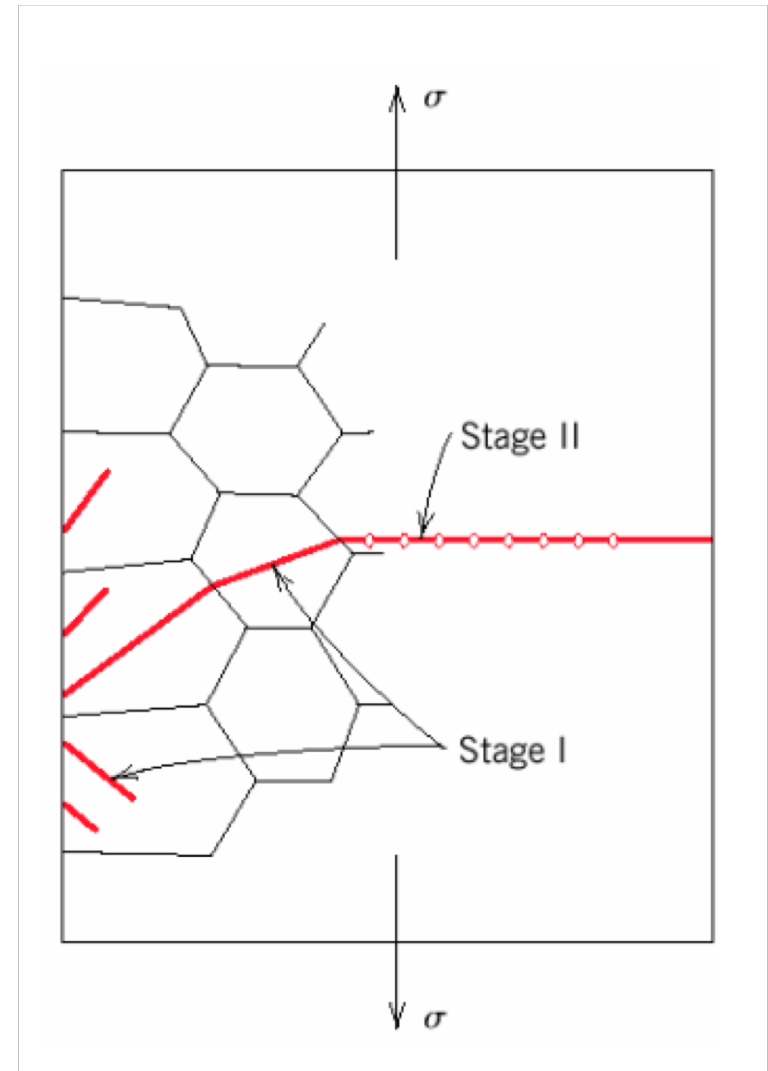

An interesting recent study



ELSEVIER

Acta Materialia

Volume 166, March 2019, Pages 56-66



Full length article

Improved fatigue resistance of gradient nanograined Cu

Jianzhou Long ^{a, 1}, Qingsong Pan ^{a, 1}, Nairong Tao ^a, Ming Dao ^b, Subra Suresh ^c ✉, Lei Lu ^a ✉



^a Shenyang National Laboratory for Materials Science, Institute of Metal Research, Chinese Academy of Sciences, Shenyang, 110016, People's Republic of China

^b Department of Materials Science and Engineering, Massachusetts Institute of Technology, Cambridge, MA, 02139, USA

^c Nanyang Technological University, Singapore, 639798, Republic of Singapore

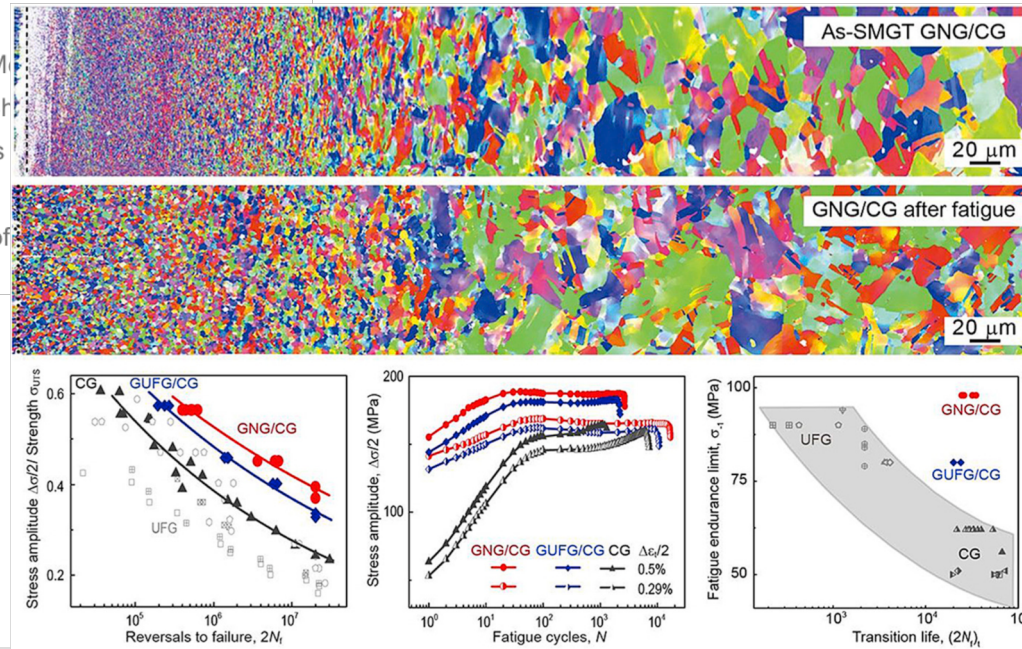

Fractography of fatigue failure

Two types of markings

- Beachmarks (해변 무늬 – 혹은 clamshell markings) – 육안으로 판별 가능 Fig. 10.22
- Striations (줄무늬) – 매우 작아 SEM, TEM 관찰 – Fig. 23

위의 마킹들은 특정 순간 마다의 crack tip의 위치 – 나무의 나이테처럼 ; 비록 작은 외부의 응력이라도 stress concentration 으로 인해 crack tip은 소성변형 가능; 이런 marking들은 이런 소성 변형의 흔적.

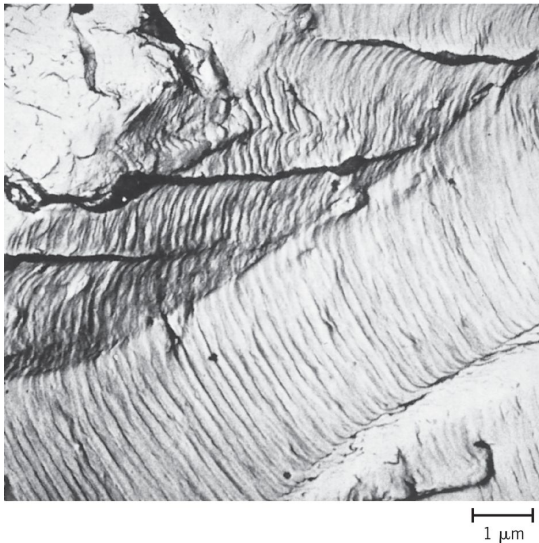

Fig. 23

From V. J. Colangelo and F. A. Heiser, Analysis of Metallurgical Failures, 2nd edition. Copyright © 1987 by John Wiley & Sons, New York. Reprinted by permission of John Wiley & Sons, Inc.

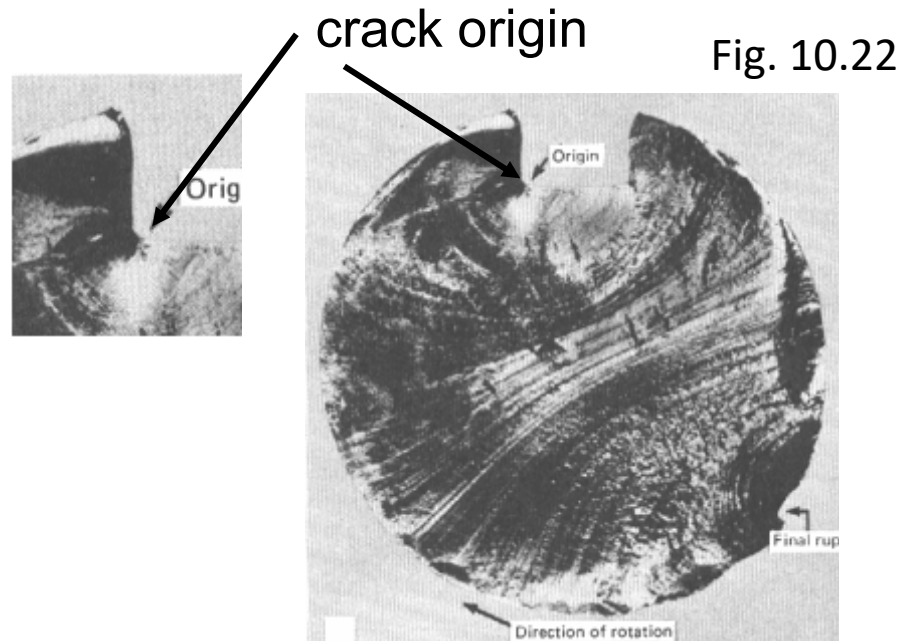
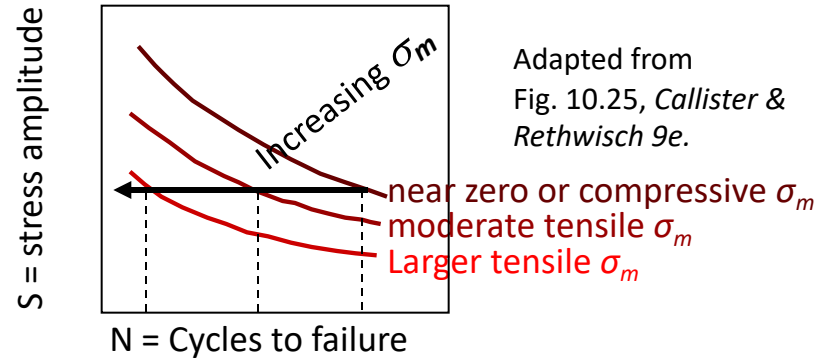

Fig. 10.22

How to Improve Fatigue Life (Read Ch 10.10)

1. Impose compressive surface stresses
(to suppress surface cracks from growing)



--Method 1: shot peening (Fig. 10.27)

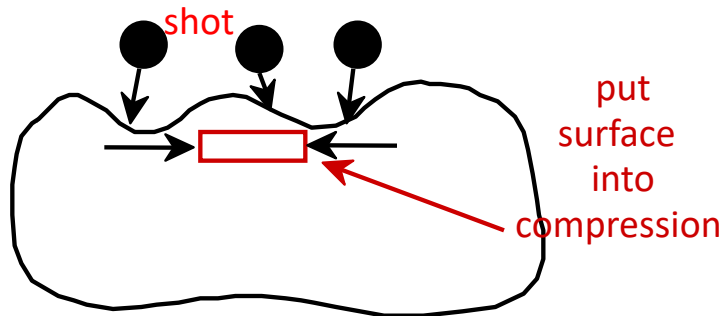

--Method 2: carburizing (see Fig. 10.28)

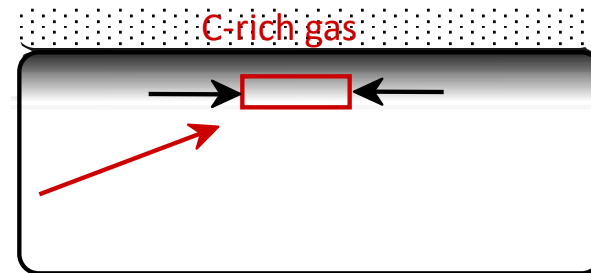

2. Remove stress concentrators.

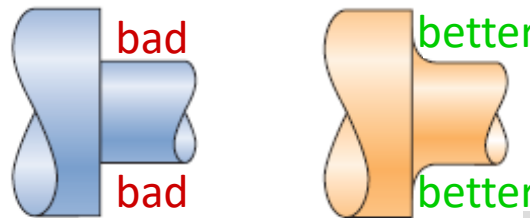

Fig. 10.26, Callister & Rethwisch 9e.

Other factors

- Thermal (thermal cyclic fatigue) – 열피로
 - 기계적 응력 없이, 고온에서의 온도 변화로 인한 피로.
 - 온도 변화는 '열팽창' 및 '열수축'으로 이어진다. 이로 인해 온도 변화에 따른 응력 발생
- Corrosion fatigue
 - Combination of stress and chemical attacks.
 - Stress Corrosion Cracking (SCC)

Creep; and three stages in creep rate

Sample deformation at a constant stress (σ) vs. time

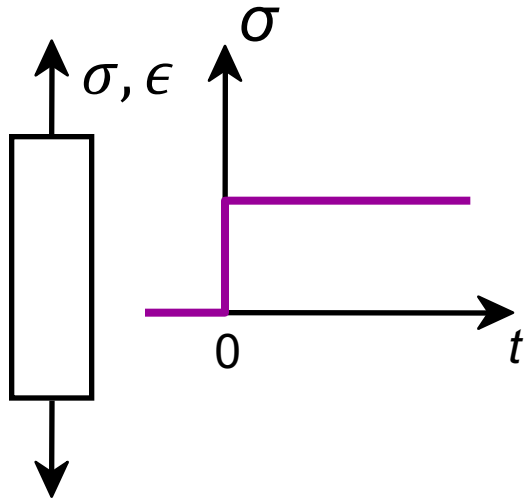

Adapted from
Fig. 10.29, *Callister &
Rethwisch 9e.*

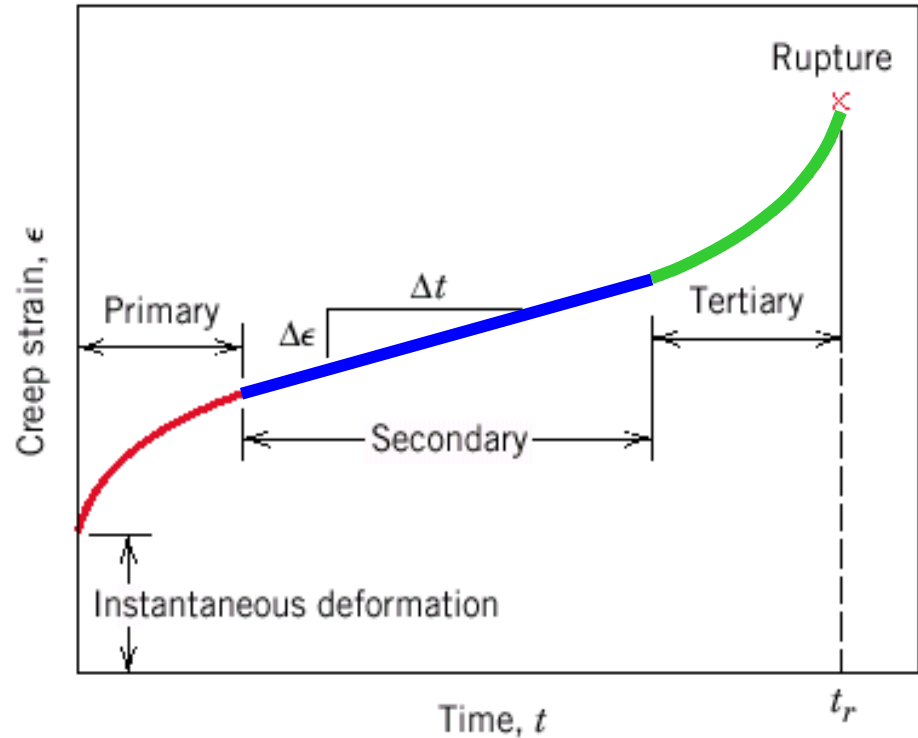

Primary Creep: slope (creep rate) **decreases** with time

Secondary Creep: steady-state

i.e., constant slope ($\Delta\epsilon/\Delta t = \text{constant}$); constant creep rate

Tertiary Creep: slope (creep rate) **increases** with time

Creep; Creep test under constant load

■ 흐름흐물 변형

■ Deformation under 'static' load / Stress changes under 'static' deformation – here by static means a 'fixed' constant load or deformation.

■ **Time-dependent** and **permanent** deformation.

■ Creep tests divided into two controls:

- Static load control
- Static deformation control

■ For metal alloys for structures, creep usually occurs at high temperature ($0.4 > T/T_m$)

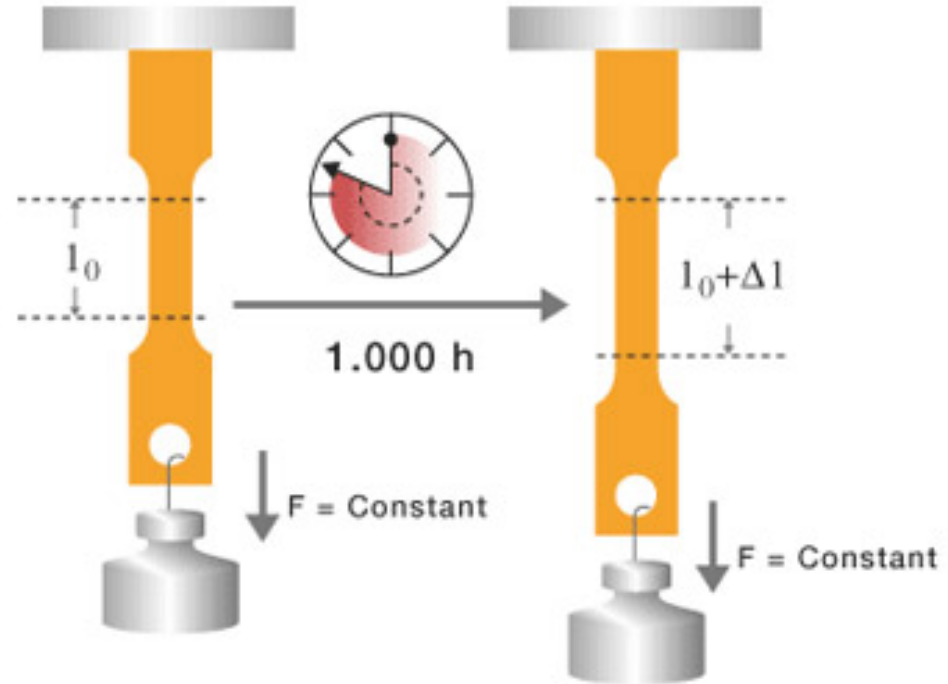

Creep test under constant load

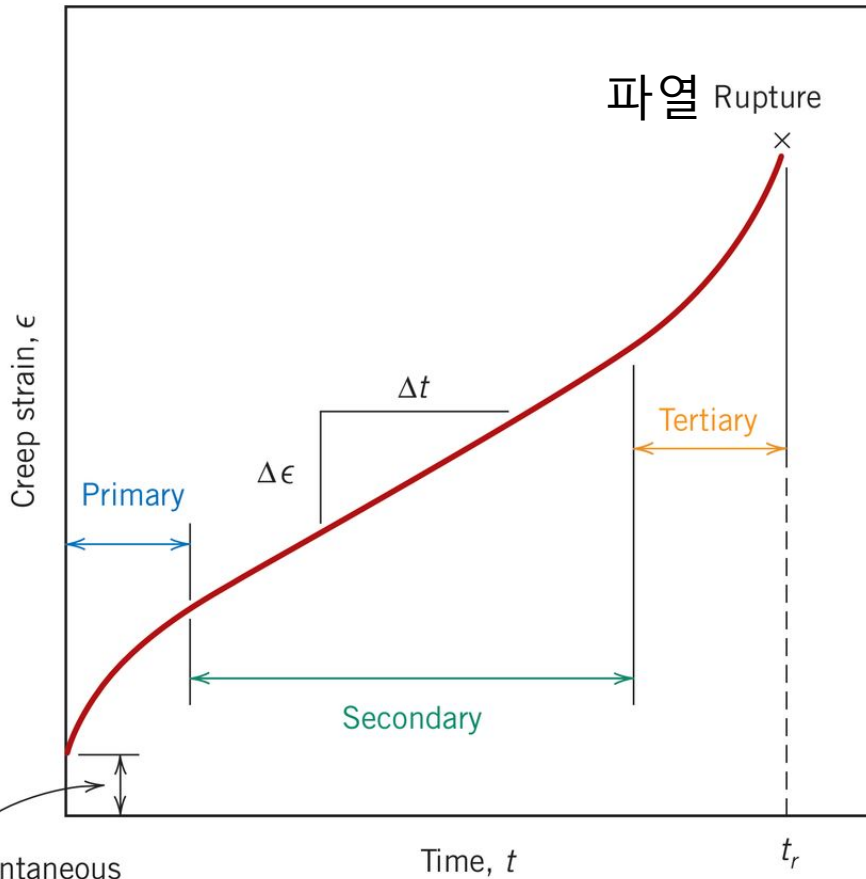

1. Instantaneous deformation: 하중이 가해지는 순간 즉시 발생; Elastic
2. Primary creep (1차 크리프) / transient creep (전이 크리프); strain hardening occurs thus creep strain rate decrease
3. Secondary creep (steady-state creep 정상 크리프)
4. Tertiary (3차 크리프); creep strain rate increases; due to necking;
5. Rupture (pulls apart);

Two parameters from creep test

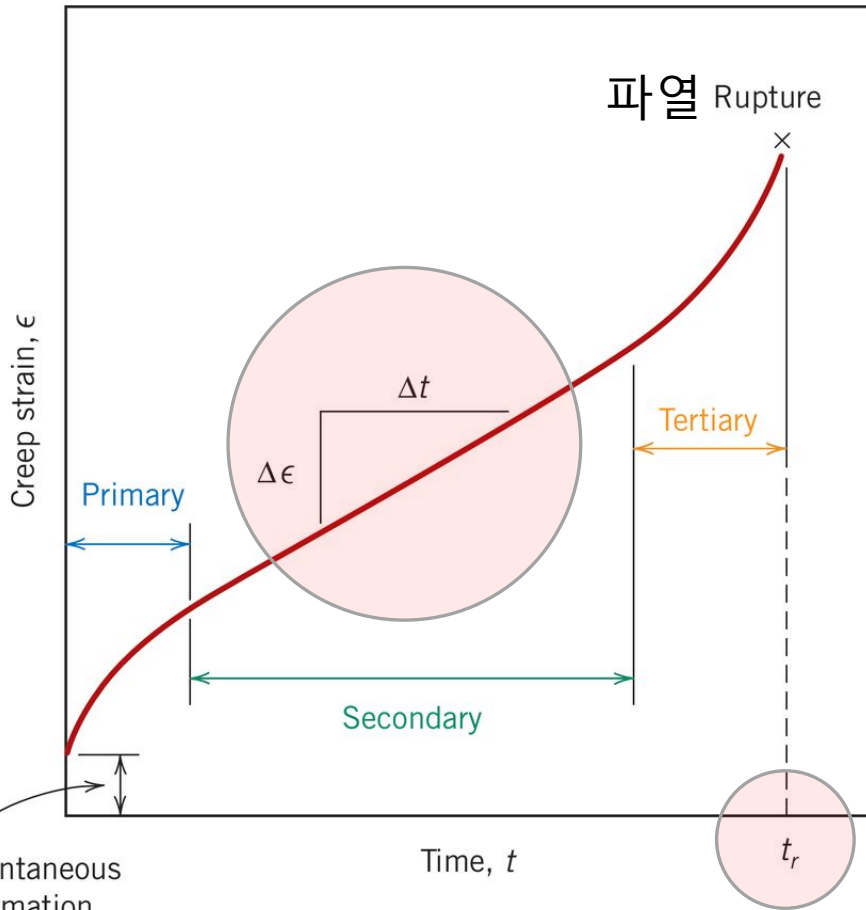

■ 정상 크리프 구간에서의 $\Delta\epsilon/\Delta t$ ($\dot{\epsilon}_s$) 를 정상 크리프 속도 (steady-state creep rate). 원자로용 재료; creep resistant materials for long-term usage.

■ 파열시간: t_r ; 예상수명이 짧은 경우, 예를 들어 군용기의 turbine blade, rocket motor nozzle.

Creep characteristics는 크게 작용 **응력**과 **온도**에 영향을 받는다.

Creep: Temperature Dependence

Creep characteristics는 크게 작용 응력과 온도에 영향을 받는다.

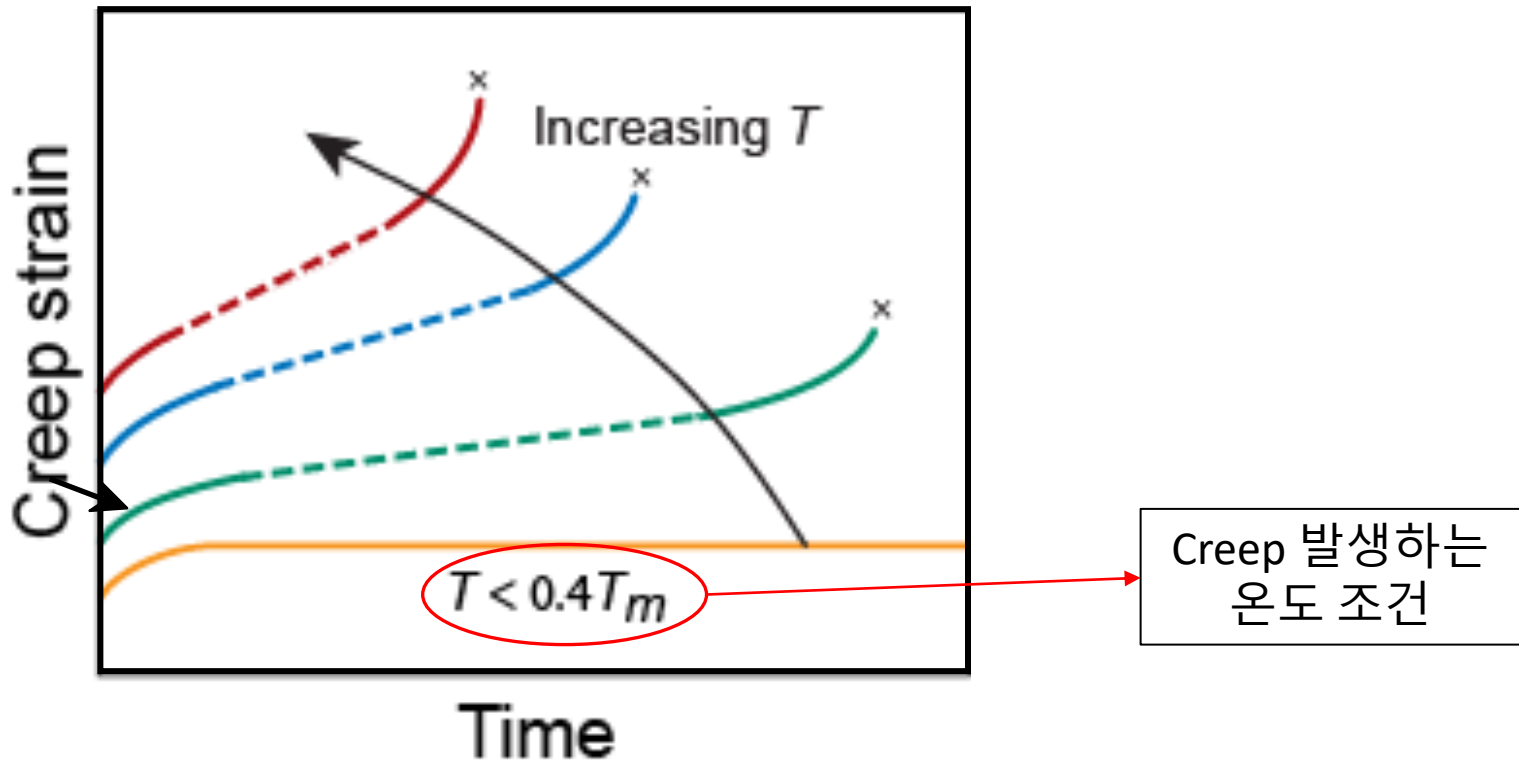

Figs. 10.30, Callister & Rethwisch 9e.

Creep characteristic affected by stress

Creep characteristics는 크게 작용하는 응력과 온도에 영향을 받는다.

$\dot{\epsilon}_s = K_1 \sigma^n$ (지수 함수의 형태로 steady creep rate / stress 관계 나타낸다.)

정상 크리프 속도(creep rate at the steady-state)의 응력 의존성을 지수함수식으로 설명

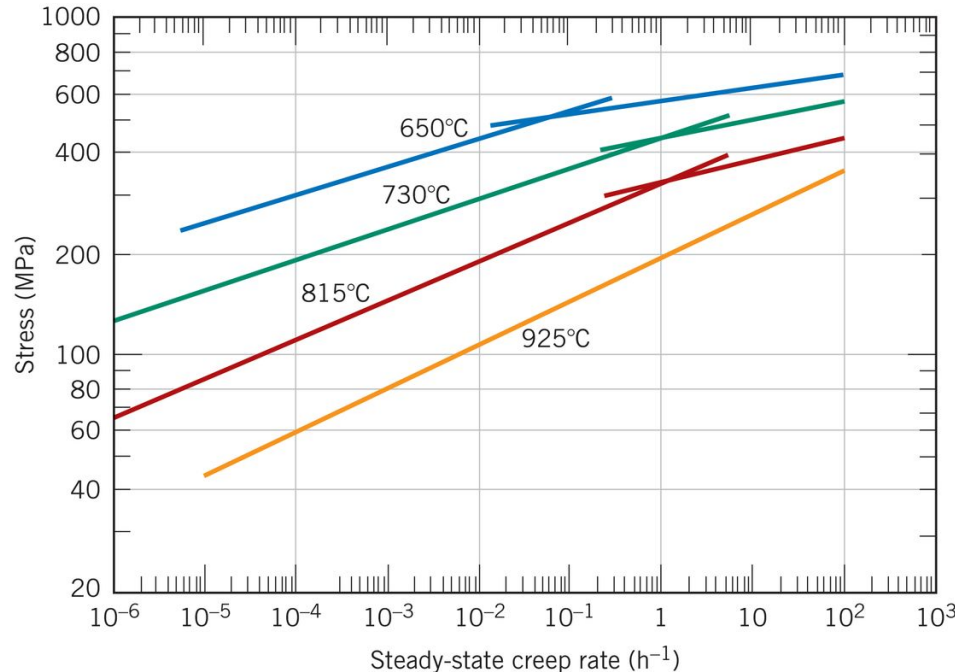

$$\ln \dot{\epsilon}_s = n \ln \sigma + \ln K_1$$

$$\ln \sigma = \frac{1}{n} \ln \dot{\epsilon}_s - \frac{1}{n} \ln K_1$$

y=ax +b 의 형태 (즉, 선형 관계)
즉 logarithmic stress/logarithmic steady-state creep rate는 선형 관계로 나타남

Creep characteristic affected by stress and temperature

$$\dot{\epsilon}_s = K_2 \sigma^n \exp\left(-\frac{Q_c}{RT}\right)$$

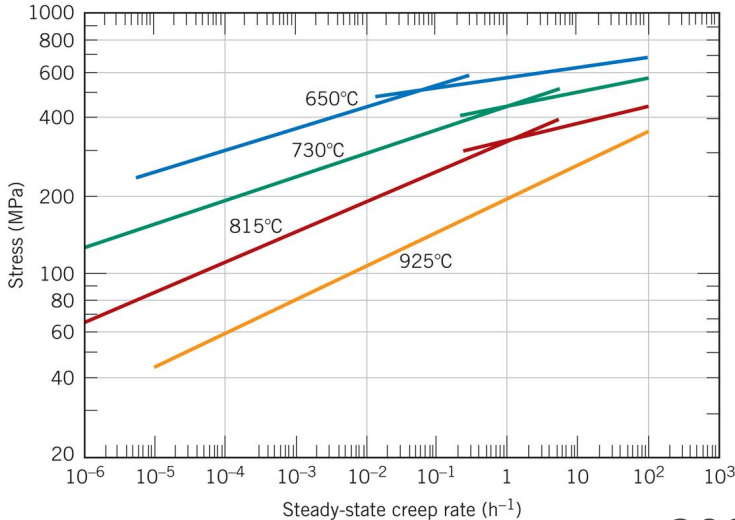

Reprinted with permission of ASM International. © All rights reserved. www.asminternational.org

온도 구간에 따라 다른 '기울기'. 이는 온도에 따라 n , Q_c 값이 달라지기 때문.
 n 과 Q_c 값이 변하는 이유는 creep 의 mechanism이 달라지기 때문이다.

- 기공확산 (vacancy diffusion)
- 입계확산 (grain boundary diffusion)
- 전위 이동 및 입계 슬립 (grain boundary sliding)

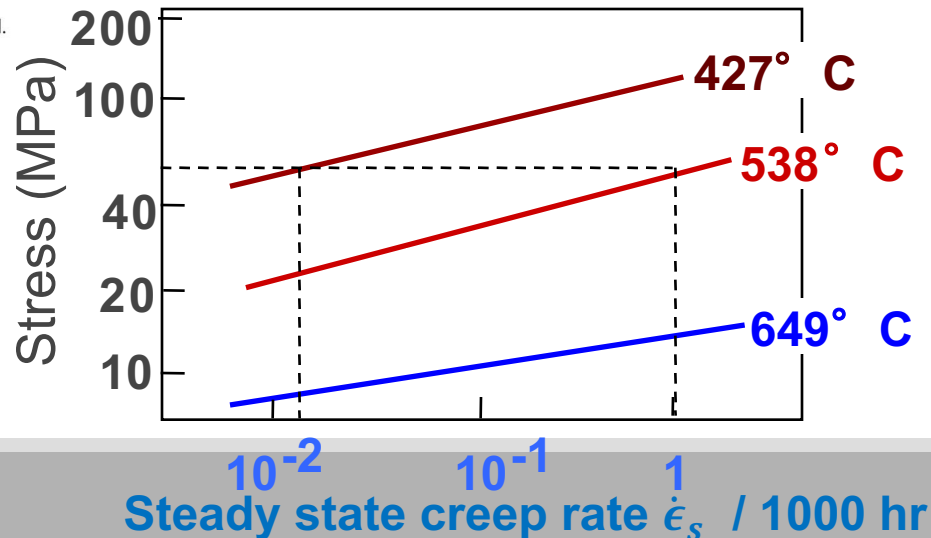

Adapted from Fig. 9.38, Callister & Rethwisch 4e. [Reprinted with permission from *Metals Handbook: Properties and Selection: Stainless Steels, Tool Materials, and Special Purpose Metals*, Vol. 3, 9th ed., D. Benjamin (Senior Ed.), ASM International, 1980, p. 131.]

- (Steady-state) creep rate increases with increasing T , σ

Creep Failure

- Failure: along grain boundaries.

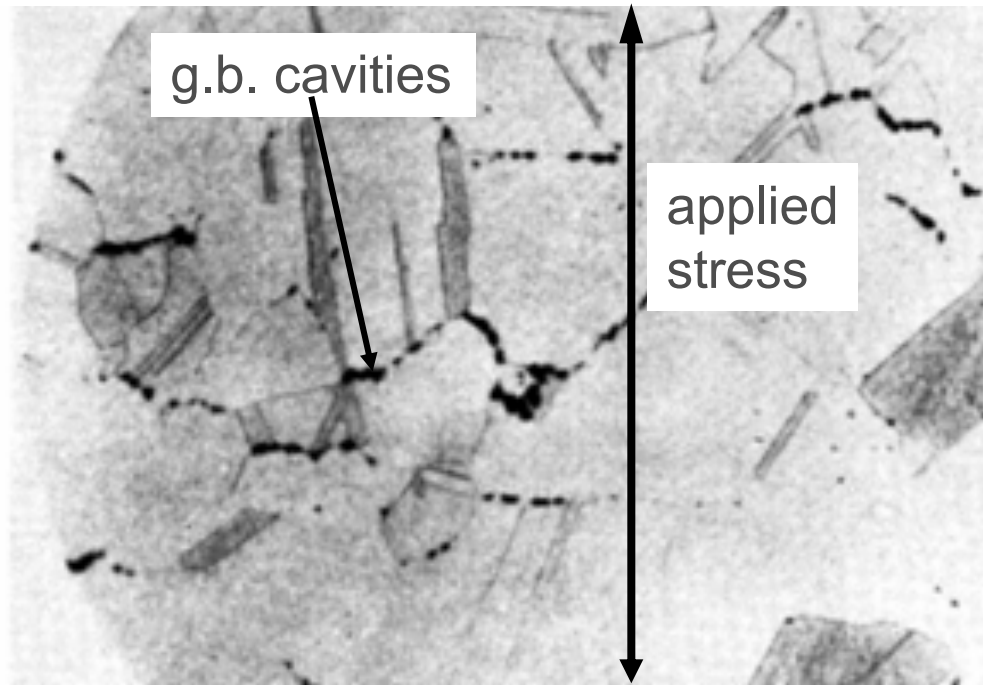

From V.J. Colangelo and F.A. Heiser, *Analysis of Metallurgical Failures* (2nd ed.), Fig. 4.32, p. 87, John Wiley and Sons, Inc., 1987. (Orig. source: Pergamon Press, Inc.)

Data extrapolation methods

- Need creep data for testing conditions that require impractically long time to collect the experimental data (years of testing time – e.g., materials used for nuclear power plants)
- One way to obtain experimental data for prolonged tests is **to impose an excessively harsh conditions (higher temperature than in-service condition)** to shorten the time periods.
- You are ‘extrapolating’ the data since you ‘guess’ the behavior that you actually didn’t measure.
- A common extrapolation procedure employs Larson-Miller parameter (m) defined as
$$m = T(C + \log t_r)$$
- We assume the Larson-Miller parameter (m) is a constant.

Example

- Your task is to conduct the rupture-test for an alloy that obeys Larson-Miller parameter:
 - $m = T(20 + \log t_r) = \text{CONSTANT}$
- Your boss asked you to test the material at **700K** which is expected to complete in a year.
- If you want to finish the test in a month, what should you do? The answer is you have to give impose the specimen **a harsher condition than 700K**.
- $T_1(20 + \log t_{r,(1)}) = T_2(20 + \log t_{r,(2)})$
- $700K \times [20 + \log(24h \times 365)] = T_2(20 + \log 24h \times 30)$
- Solve for T_2 . 단위에 주의!

SUMMARY

- Engineering materials not as strong as predicted by theory
- **Flaws act as stress concentrators** that cause failure at stresses lower than theoretical values.
- Sharp corners (crack ..) produce large stress concentrations and premature failure.
- Failure type depends on T and σ :
 - For **simple fracture** (noncyclic σ and $T < 0.4T_m$), failure stress decreases with:
 - increased maximum flaw size,
 - decreased T ,
 - increased rate of loading.
 - For **fatigue** (cyclic σ):
 - cycles to fail decreases as $\Delta\sigma$ increases.
 - For **creep** ($T > 0.4T_m$):
 - time to rupture decreases as σ or T increases.

References

- <http://jpkc.fudan.edu.cn/picture/article/348/1b/ee/6dce0ae740cf8673b53e4e96abb8/6ad0c8ee-53c3-4790-a931-211df202df69.pdf>
- <http://people.virginia.edu/~lz2n/mse209/Chapter8.pdf>
- Fracture Mechanics – Fundamentals and Application by TL Anderson.